



CURRENT TRANSFORMERS

Model 8 (Window Size: 3.25" Diameters)

Application: Metering

Frequency: 50-400 Hz

Insulation Level: 600 Volts, 10Kv BIL Full Wave

- Flexible leads available for all case configurations. Flexible leads are UL 1015 105°C, C.S.A approved #16 AWG, 24" long standard length. Non-standard lengths are available upon request.
- Terminals are brass studs No. 8-32 UNC with one flat washer, one lock washer and one nut each. Terminals are only available on the square case configuration.
- Mounting brackets kits for the Model 8SHT are available when required.
- Approximate weight: 3 lbs.

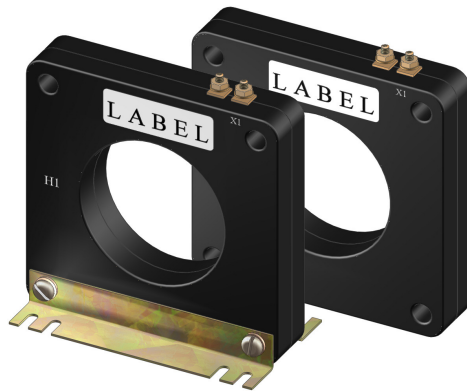

8 SHT

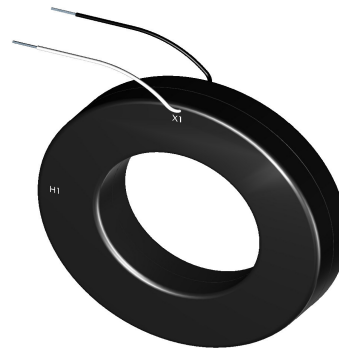

8 RL

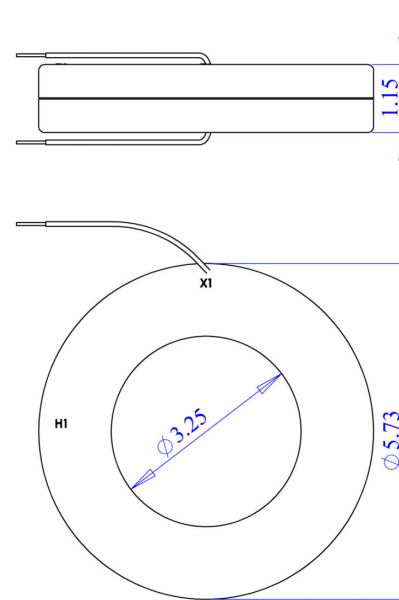
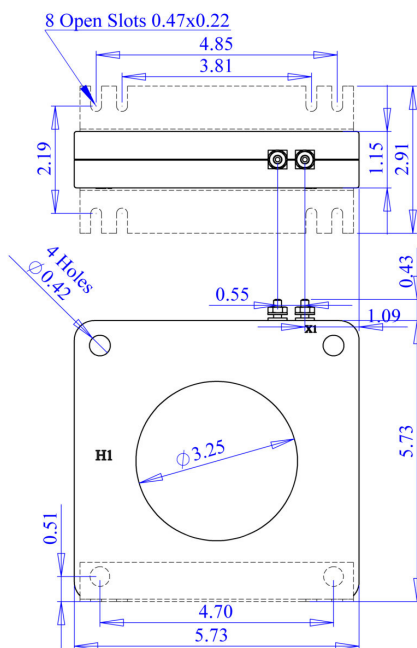

*Note-Mounting brackets for the 8SHT and 8SHL are sold separately (Part Number 1121A00022-1)



CURRENT TRANSFORMERS

Model 170 (Window Size: 4.25" Diameter)

Catalog Number	Current Ratio	VA +/- 1% Class	ANSI Metering Class at 60 Hz.					Secondary Winding Resistance Ohms at 75°C	Continuous Thermal Rating Factor	
			B0.1	B0.2	B0.5	B0.9	B1.8		at 30°C	at 55°C
8**-201	200:5	5.0	1.2	1.2	2.4	4.8	4.8	0.030	2.0	2.0
8**-251	250:5	7.5	0.6	0.6	1.2	2.4	4.8	0.044	2.0	2.0
8**-301	300:5	15.0	0.6	0.6	1.2	2.4	2.4	0.049	2.0	2.0
8**-401	400:5	25.0	0.3	0.3	0.6	1.2	2.4	0.079	2.0	1.5
8**-501	500:5	35.0	0.3	0.3	0.6	0.6	1.2	0.102	2.0	1.5
8**-601	600:5	50.0	0.3	0.3	0.6	0.6	1.2	0.147	1.5	1.33
8**-751	750:5	50.0	0.3	0.3	0.6	0.6	1.2	0.184	1.5	1.0
8**-801	800:5	60.0	0.3	0.3	0.3	0.6	0.6	0.197	1.5	1.0
8**-102	1000:5	75.0	0.3	0.3	0.3	0.6	0.6	0.246	1.33	1.0
8**-122	1200:5	75.0	0.3	0.3	0.3	0.3	0.6	0.274	1.33	1.0
8**-152	1500:5	90.0	0.3	0.3	0.3	0.3	0.6	0.316	1.33	1.0
8**-162	1600:5	100.0	0.3	0.3	0.3	0.3	0.6	0.337	1.33	0.8
8**-202	2000:5	120.0	0.3	0.3	0.3	0.3	---	0.422	1.0	0.8
8**-252	2500:5	50.0	0.3	0.3	0.3	0.3	--	0.438	1.0	0.8
8**-302	3000:5	60.0	0.3	0.3	0.3	0.3	--	0.526	1.0	0.8
8**-352	3500:5	70.0	0.3	0.3	0.3	0.3	---	0.561	1.0	0.8
8**-402	4000:5	80.0	0.3	0.3	0.3	0.3	---	0.973	0.8	0.8

**Note: When ordering, use prefix below to indicate unit designation/configuration.
(i.e. 8SHT-101)

*SHT= Square Case w/o molded feet and terminals

*SHL= Square Case w/o molded feet and 24" leads

RL= Thin Round Case and 24" leads

*Note-Mounting Brackets for the 8SHT and 8SHL Part Number 1121A00022-1



CURRENT TRANSFORMERS

Model 8

