

## TOROIDAL CURRENT TRANSFORMERS

Model 781-402MR Ratio to 5 (Window Size: 6.50" Dia.)

**Application:** Used with ammeters, watt meters and cross current compensation.

**Frequency:** 50-400 Hz

**Insulation Level:** 600 Volts, 10kV BIL Full Wave

**Standards:** CSA 66.1-06, CSA 66.2-06, IEEE C 57.13, and UL 506

- Terminals are Female Brass No. 10-32 UNC with one flat washer, one lock washer and one pan head screw each.
- Mounting Bracket Kits are sold separately. (P/N Bracket 780 Kit-3)
- Approximate weight: 30 lbs.

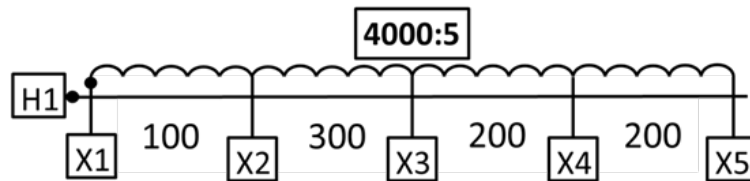
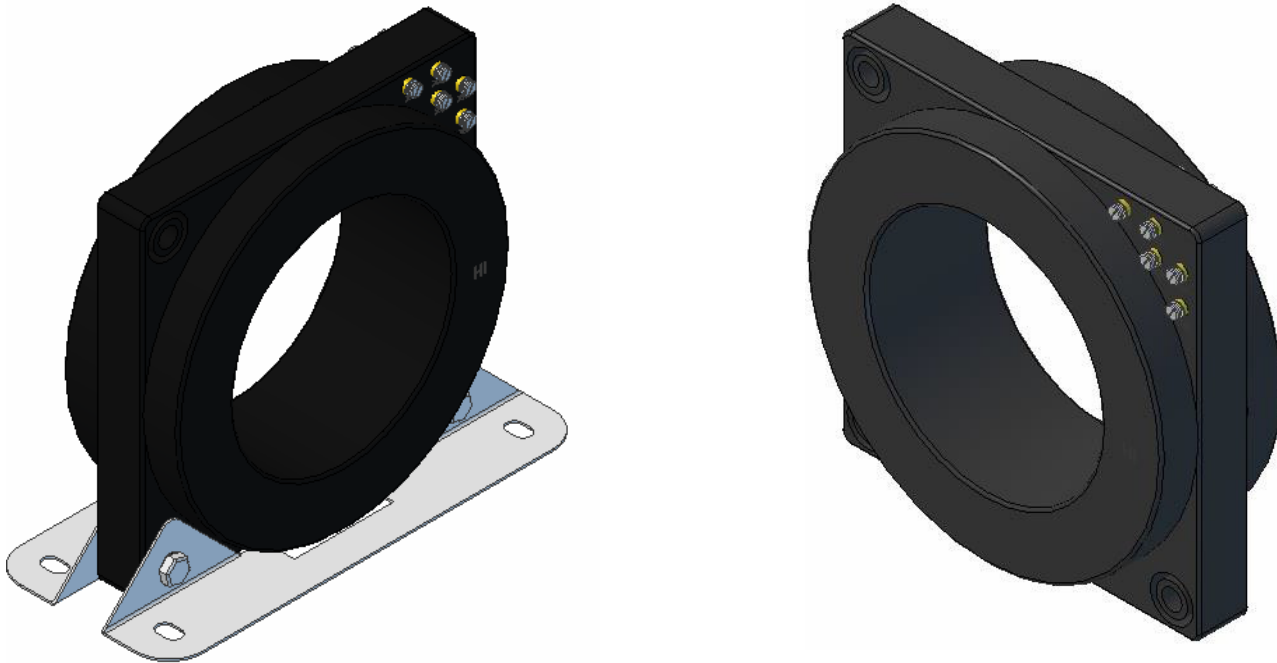

## TOROIDAL CURRENT TRANSFORMERS

Model 781-402MR Ratio to 5 (Window Size: 6.50" Dia.)

Model	Ratio	Terminal Designation	Relay Class	ANSI METERING CLASS AT 60 Hz					Secondary Winding Resistance
				B0.1	B0.2	B0.5	B0.9	B1.8	
781-402MR	500:5	X1 - X2	C20	0.6	0.6	1.2	1.2	2.4	0.134
781-402MR	1000:5	X3 - X4	C50	0.3	0.3	0.3	0.6	0.6	0.278
781-402MR	1500:5	X2 - X3	C50	0.15	0.15	0.3	0.3	0.3	0.393
781-402MR	2000:5	X1 - X3	C100	0.15	0.15	0.15	0.3	0.3	0.53
781-402MR	2500:5	X2 - X4	C100	0.15	0.15	0.15	0.3	0.3	0.667
781-402MR	3000:5	X1 - X4	C100	0.15	0.15	0.15	0.15	0.3	0.804
781-402MR	3500:5	X2 - X5	C200	0.15	0.15	0.15	0.15	0.15	0.953
781-402MR	4000:5	X1 - X5	C200	0.15	0.15	0.15	0.15	0.15	1.075

## TOROIDAL CURRENT TRANSFORMERS

Model 781-402MR Ratio to 5 (Window Size: 6.50" Dia.)

**Model 781**

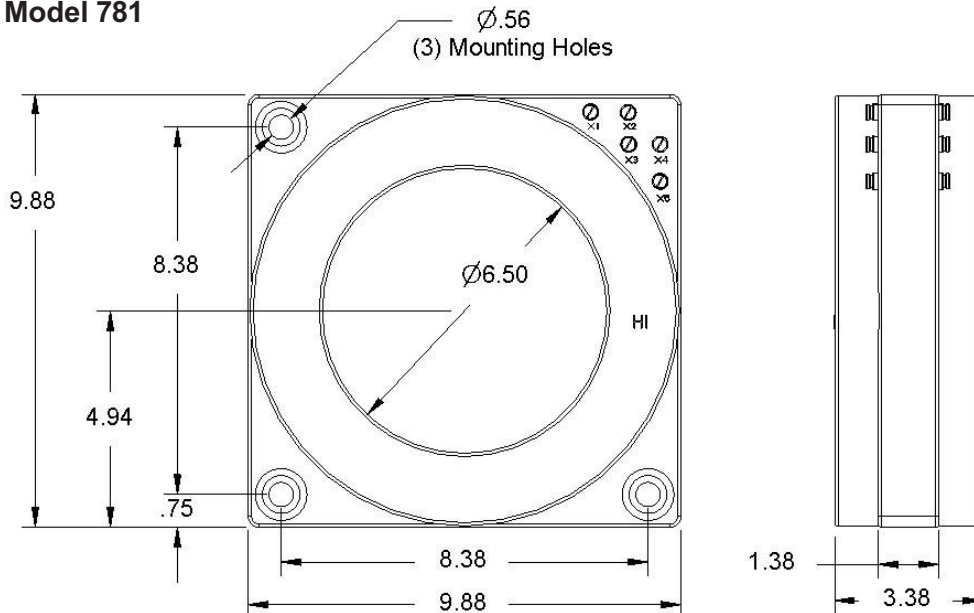

**Model 781  
 With Brackets**

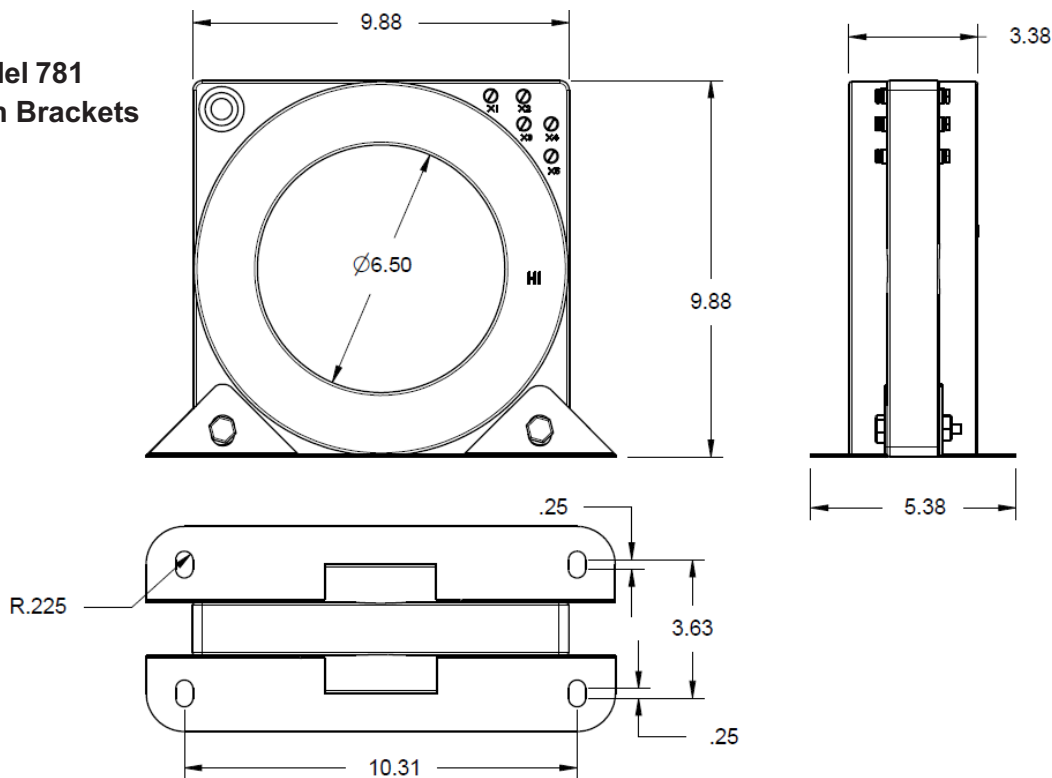

Rev F 06 12 2024