

TOROIDAL CURRENT TRANSFORMERS

Model 8 Ratio to 1 (Window Size: 3.25" Dia.)

Application: Metering

Frequency: 50-400 Hz

Insulation Level: 600 Volts, 10Kv BIL Full Wave

Standards: CSA 66.1-06, CSA 66.2-06, IEEE C 57.13, and UL 506

- Flexible leads available for all case configurations. Flexible leads are UL 1015 105°C, C.S.A approved #16 AWG, 24" long standard length. Non-standard lengths are available upon request.
- Terminals are brass. See page 2 for available Stud and Female hardware options.
- Terminals are only available on the square case configuration.
- Mounting bracket kits for the Model 8SHT or 8SHL are available.
- Approximate weight: 3 lbs.

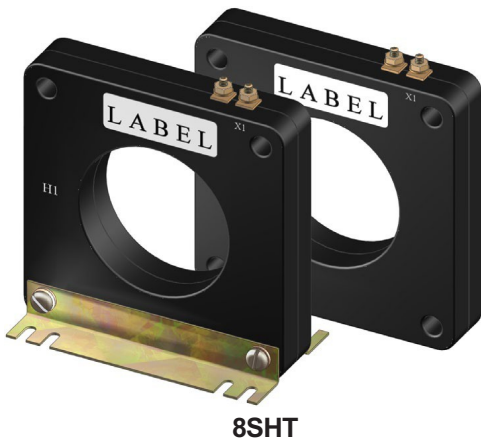

8SHT

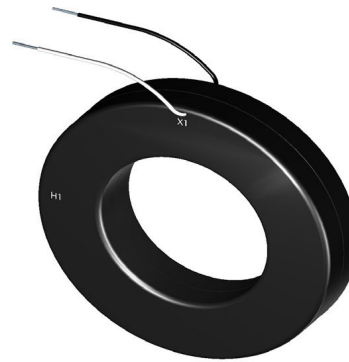

8RL

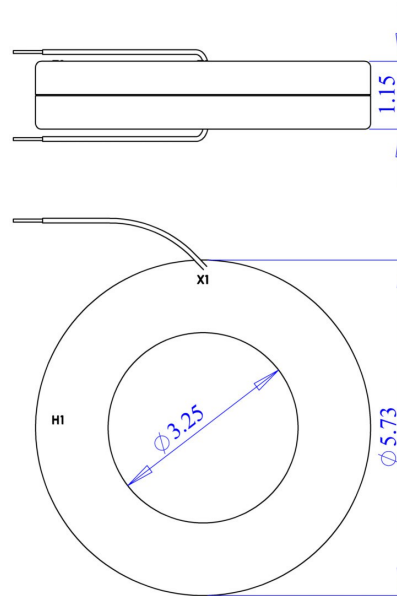
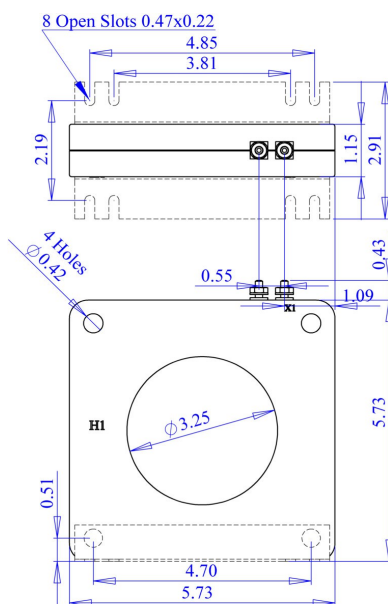

*Note-Mounting bracket kits for the Model 8SHT and 8SHL are sold separately (Part Number 1121A00022-1)

Rev F 06 12 2024

TOROIDAL CURRENT TRANSFORMERS

Model 8 Ratio to 1 (Window Size: 3.25" Dia.)

Catalog Number	Current Ratio	ANSI METERING CLASS AT 60 HZ				
		B0.1	B0.2	B0.5	B0.9	B1.8
8**-101-1	100:1	1.2	—	—	—	—
8**-121-1	120:1	1.2	—	—	—	—
8**-151-1	150:1	1.2	2.4	—	—	—
8**-201-1	200:1	1.2	1.2	—	—	—
8**-251-1	250:1	0.6	0.6	2.4	—	—
8**-301-1	300:1	0.6	0.6	2.4	—	—
8**-401-1	400:1	0.3	0.3	1.2	2.4	—
8**-501-1	500:1	0.3	0.3	0.6	1.2	2.4
8**-601-1	600:1	0.3	0.3	0.3	0.6	2.4
8**-751-1	750:1	0.3	0.6	0.6	0.6	2.4
8**-801-1	800:1	0.3	0.3	0.3	0.6	1.2
8**-102-1	1000:1	0.3	0.3	0.3	0.6	1.2
8**-122-1	1200:1	0.15	0.15	0.15	0.3	0.6
8**-152-1	1500:1	0.15	0.15	0.15	0.3	0.3
8**-182-1	1800:1	0.15	0.15	0.15	0.15	0.3
8**-202-1	2000:1	0.15	0.15	0.15	0.15	0.3

ORDERING NOTE*: When ordering, use the prefix below to indicate unit designation/configuration. (i.e. 8SHT-101-1)

RL = Thin Round Case with Standard 24" leads (Non-standard lengths are available upon request)

SHX* = Square Case with mounting holes

T = Male (Brass studs No. 8-32 UNC with one flat washer, one lock washer and one nut each)

Y = Female (Brass with one Cup washer, one lock washer and one No. 8-32 UNC binding head screw each)

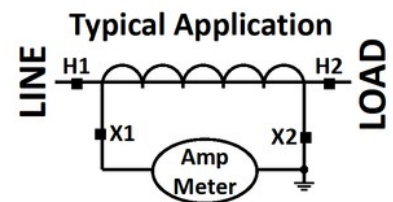
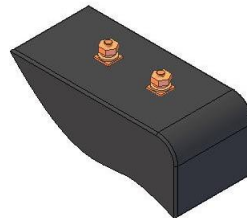
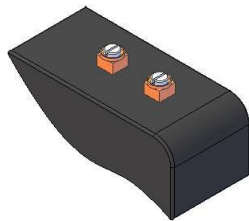
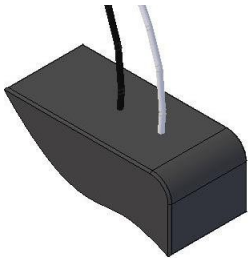

L = 16awg Lead Wire Y = Female Terminals T = Male Terminals

*X is to be replaced with "L", "Y" or "T" for terminal or lead designation.

*Note-Mounting bracket kits for the Model 8SHT and 8SHL are sold separately (Part Number 1121A00022-1)