

GROUND FAULT CURRENT DETECTION (with Inverse Time Capabilities)

Model GFP Relay [5-60 | 30-360 | 100-1200A]

The GFP system is designed for electrical equipment protection, not for personnel protection.

Application: These Class 1 (Model GFP) Ground Fault relays and sensors are used together to provide a system for detecting ground fault current in a grounded AC power system. When the system detects a ground fault that reaches a pre-selected current level and time delay, the relay initiates a trip signal for a shunt trip disconnect device to open and clear the fault.

The relays are also available with interlocks (for coordination of multiple devices in a system) and without interlocks (for single device systems).

The GFP non-interlock relays form/fit/function replacements for the BGFL Ground Fault relay without interlock.

Operating Range: Trip currents models are available for 5-60, 30-360, and 100-1200A. The time delay is adjustable from instantaneous to 1 second.

Input Power: Three Phase 208, 240, 480, 575, or 600Vac

Input Withstand: 200,000 Amperes RMS for 3 cycles, 50/60 Hz.

Nominal Input Voltage: Input power comes from the three phases being monitored.

Frequency: 50/60 Hz.

Ambient Temperature Range: -30 Deg C. to 60 Deg C.

- Two (2) Styles "Standard" (without interlock) and "Zone Interlocking".
- Integral test panel with "Push to Test" and "Shunt Trip Bypass" pushbuttons for proper testing of device with the ability to trip or not to trip the protective device.
- Power On Indication (LED).
- Real time fault current level indicator (indicating actual value of trip set point).
- Positive visual trip indicator.
- Indication of fault current level at trip after unit has tripped.
- Adjustable time delay with three-time delay characteristics options
- Discrete current threshold adjustment.
- Panel or door mounted.
- Clear plastic cover.
- Electro-mechanical relay output positive "ON" and "OFF".
- Operates with molded case power circuit breakers, bolted pressure switches, or fusible disconnect switches.
- Optional "Form C" contacts.
- Meets NEC service entrance equipment standards.

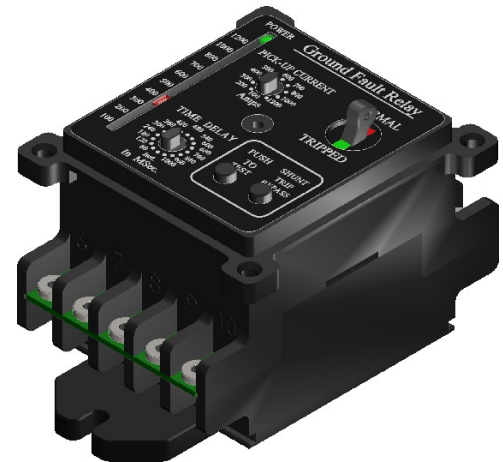

For Dimensional and physical installation Information see sheet 8.

Contact Ratings		
Device Input Power	Inrush	Continuous
120 VAC	10 A	3A
125 VDC	1A	1A
48 VDC	4A	4A
24 VDC	8A	8A

How to Order

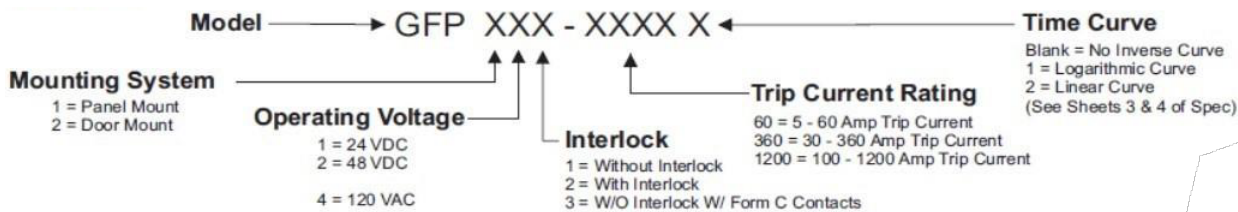

Rev F 06 12 2024

RECTANGULAR GROUND FAULT CURRENT SENSOR

Model GFP Relay [5-60 | 30-360 | 100-1200A]

The GFL system is designed for electrical equipment protection, not for personnel protection.

Application: These Ground Fault Sensors (type GFL) are available in a variety of sizes. Care should be taken when determining the physical size of the sensor window. The ground fault sensor will only respond to ground faults that occur between the position of the sensor and the load. Each sensor comes with both normal and test windings. These sensors are only for use with BGFL, GFP, and GFPV relays.

Operating Range: Trip Currents models are available for 5-60, 30-360, and 100-1200A. (trip current tolerances +/- 8%)

Frequency: 50/60 HZ

Insulation Level: 600 Volt, 10 kV BIL full wave.

- No. 8-32 brass terminals with flat washer, lock washer and nut.
- Rectangular sensors are also available with take apart option allowing installation without disassembly of the primary bus or cables.

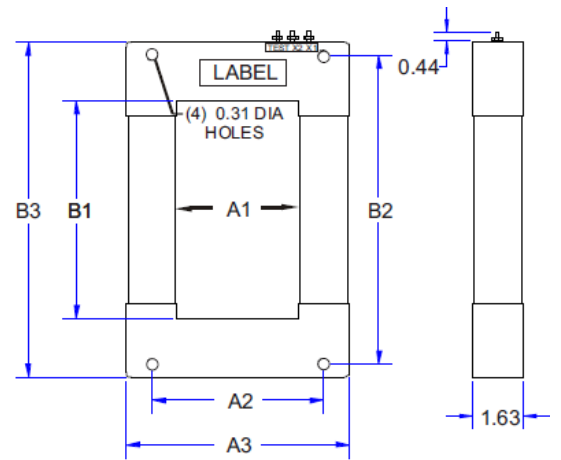

CAUTION: All appropriate safety precautions must be followed for the installation of these devices including de-energizing the incoming power prior to installation. It is recommended the sensor be installed by a trained electrician. This sensor must have its secondary terminals shorted, or have the relay connected prior to energizing the primary windings.

How to Order

- The table lists the available standard sensor sizes. Any window length can be combined with any window width. Custom sizes are also available.
- To order a rectangular sensor, use the Sensor Size Table and the Part Number Table below.
- Example: For a 10.1" x 24" window with a current trip range of 100-1200 and a split core, the part number would be "101x240SC1200".

STANDARD SENSOR SIZE					
A1	A2	A3	B1	B2	B3
4.1	6.4	7.3	7.1	10.0	10.9
5.1	7.2	8.3	11.7	14.5	15.4
5.8	7.0	9.0	14.1	17.0	17.9
8.0	9.5	11.1	18.1	21.0	21.9
10.1	11.6	13.2	24.0	27.0	27.9
x	x	x	30.1	33.0	33.9
x	x	x	36.0	38.9	39.8

GFL	Width Dim "A1" (in 1/10th of inch) See Table	BY	Length Dim "B1" (in 1/10th of inch) See Table	Split Core SC or Blank	Trip Current 5 - 60A = 60 30 - 360A = 360 100 - 1200A = 1200
GFL-	XXX	X	XXX	SC	XXXX

All Rectangular sensors built after January 1 2006 are RoHS Compliant.

TOROIDAL GROUND FAULT CURRENT SENSOR

Model GFP Relay [5-60 | 30-360 | 100-1200A]

The GFL system is designed for electrical equipment protection, not for personnel protection.

Application: These Ground Fault Sensors (type GFL) are available in a variety of sizes. Care should be taken when determining the physical size of the sensor window. The ground fault sensor will only respond to ground faults that occur between the position of the sensor and the load. Each sensor comes with both normal and test windings. These sensors are only for use with GFP, and BGFL relays.

Operating Range: Trip Currents models are available for 5-60, 30-360, and 100-1200A. (trip current tolerances +/- 8%)

Frequency: 50/60 HZ

Insulation Level: 600 Volt, 10 kV BIL full wave.

- No. 8-32 brass terminals with flat washer, lock washer and nut.



CAUTION: All appropriate safety precautions must be followed for the installation of these devices including de-energizing the incoming power prior to installation. It is recommended the sensor be installed by a trained electrician. This sensor must have its secondary terminals shorted, or have the relay connected prior to energizing the primary windings.

Trip Current 5-60 AMPS

Model Number	Sensor Dimensions					
	A1	B1	B2	C1	C2	D1
GFL325T-1	3.25	5.73	4.7	4.7	5.73	1.15
GFL425T-1	4.25	6.17	N/A	4.86	5.92	1.15
GFL631T-1	6.31	8.5	6.75	6.75	8.5	1.28
GFL825T-1	8.25	10.48	8.5	8.5	10.48	1.53

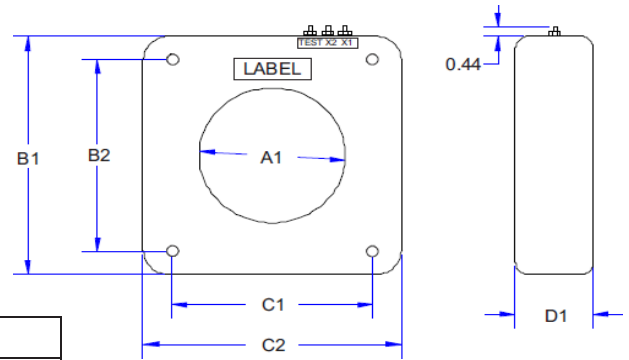

Trip Current 100-1200 AMPS

Model Number	Sensor Dimensions					
	A1	B1	B2	C1	C2	D1
GFL325T-2	3.25	5.73	4.7	4.7	5.73	1.15
GFL425T-2	4.25	6.17	N/A	4.86	5.92	1.15
GFL631T-2	6.31	8.5	6.75	6.75	8.5	1.28
GFL825T-2	8.25	10.48	8.5	8.5	10.48	1.53

Trip Current 30-360 AMPS

Model Number	Sensor Dimensions					
	A1	B1	B2	C1	C2	D1
GFL325T-3	3.25	5.73	4.7	4.7	5.73	1.15
GFL425T-3	4.25	6.17	N/A	4.86	5.92	1.15
GFL631T-3	6.31	8.5	6.75	6.75	8.5	1.28
GFL825T-3	8.25	10.48	8.5	8.5	10.48	1.53

Rev F 06 12 2024

TYPICAL RESPONSE CURVES (with Inverse Time Capabilities)

Model GFP Relay [5-60 | 30-360 | 100-1200A]

The time delay adjustment is a 16 position switch with increments ranging from Instantaneous to 1000ms

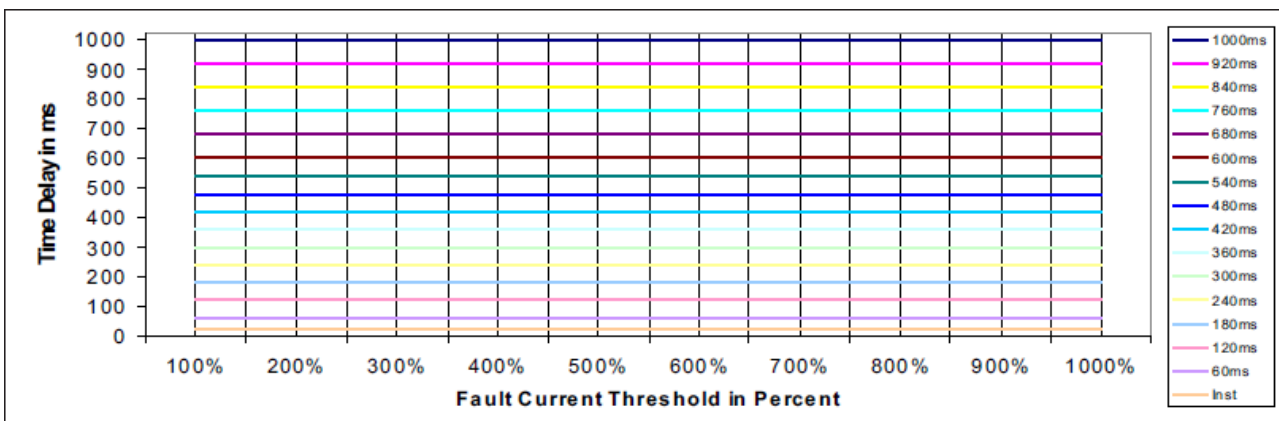
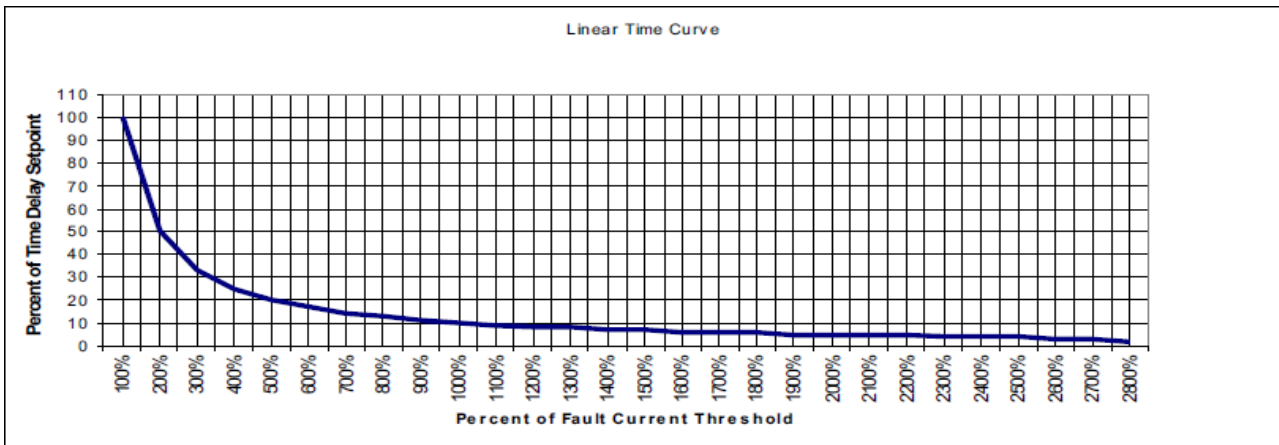
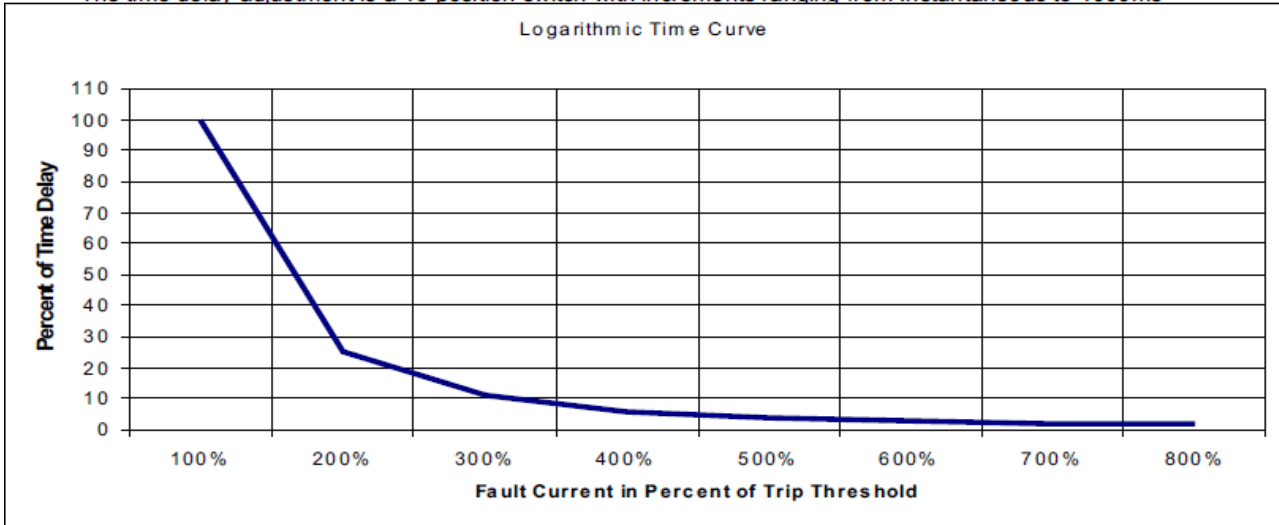

Rev F 06 12 2024

TYPICAL GFP RELAY AND SENSOR INSTALLATION

Model GFP Relay [5-60 | 30-360 | 100-1200A]

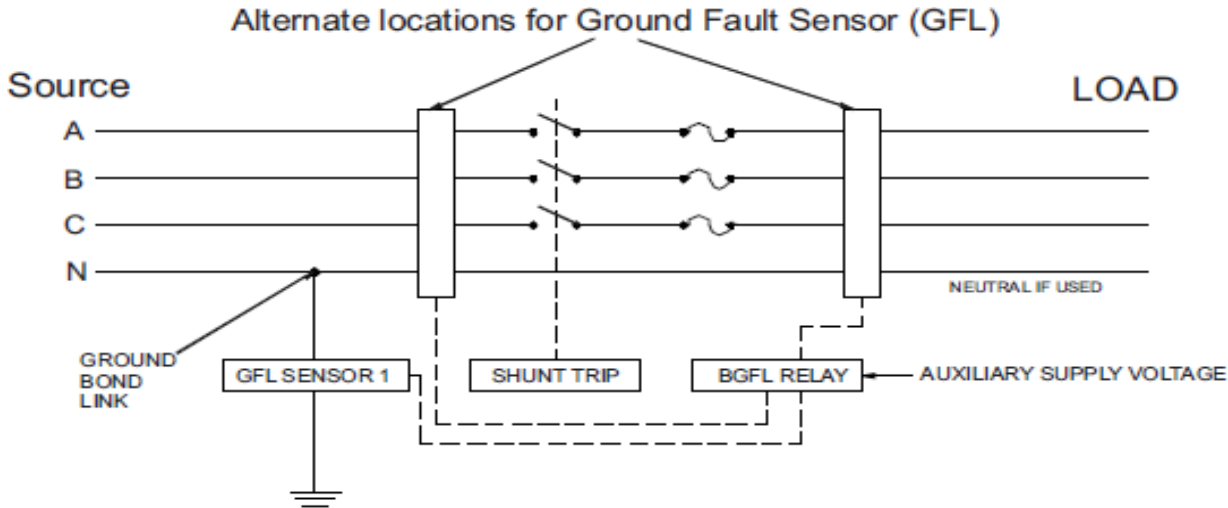

Note: NO GROUNDS PERMITTED DOWNSTREAM OF BOND LINK

CAUTION: This test should be performed by qualified personnel only.

To determine if the neutral is grounded in only one place at the service entrance in accordance with the “National Electrical Code”:

1. De-energize equipment.
 - Disconnect Power.
2. Remove ground bond link.
3. Using a megger, measure resistance of each phase and the neutral to ground.
 - In accordance with NEC requirements, the resistance should be 1 mega ohm.
4. Reconnect bond link.
5. Reconnect power and check power indication (LED)

To test the entire system (including the disconnect device):

1. Verify control power LED indicator is illuminated.
2. Press the “Push to Test” pushbutton on the GFPL box.
 - The trip indicator will go to the tripped position and the disconnect device will open.
3. Reset the relay and disconnect device.

To test the GFP Ground Fault Sensor and Relay only:

1. Verify control power LED indicator is illuminated.
2. Press and hold the “Shunt Trip Bypass” pushbutton on the GFP box.
3. Press the “Push to Test” pushbutton.
 - The Ground Fault Relay will trip.
4. Reset the relay, then release the “Shunt Trip Bypass” pushbutton.

TYPICAL GFP WIRING DIAGRAMS

Model GFP Relay [5-60 | 30-360 | 100-1200A]

Typical Wiring Diagram

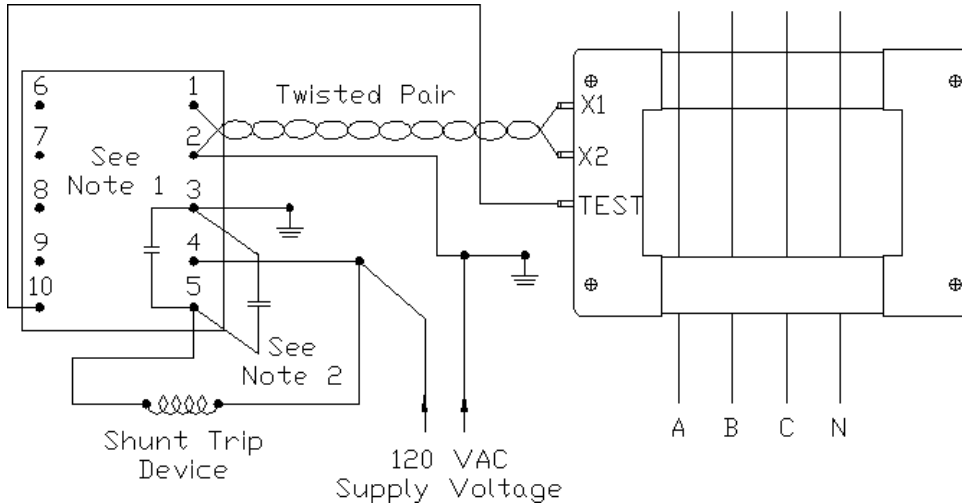

Typical Wiring Diagram for DC Powered Units

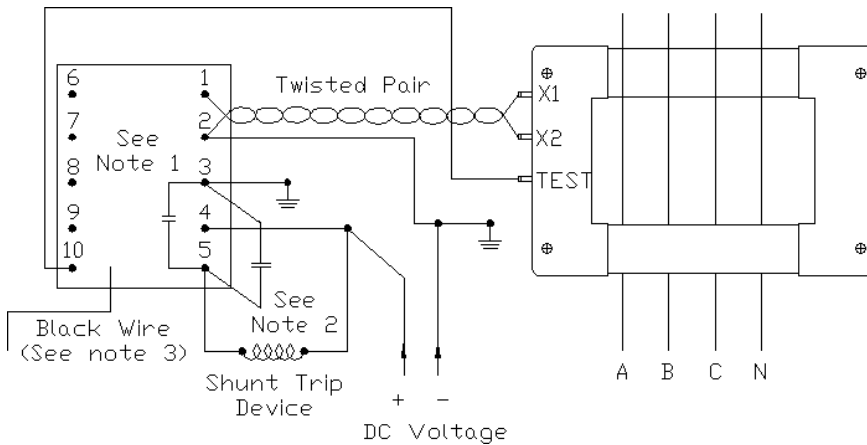

Notes:

- 1) Standard Internal Relay Contacts (NO).
- 2) Optional contact for units with "Form C" contacts may be connected in parallel across terminals 3 and 5.
- 3) Additional protective devices (NO) isolated contacts may be connected in parallel across terminals 3 and 5.
- 4) The test circuit requires 120Vac be applied to the black wire with the 120v neutral on terminal 2 or 3 of the relay.

TYPICAL GFP WIRING DIAGRAM FOR ZONE INTERLOCK SYSTEM

Model GFP Relay [5-60 | 30-360 | 100-1200A]

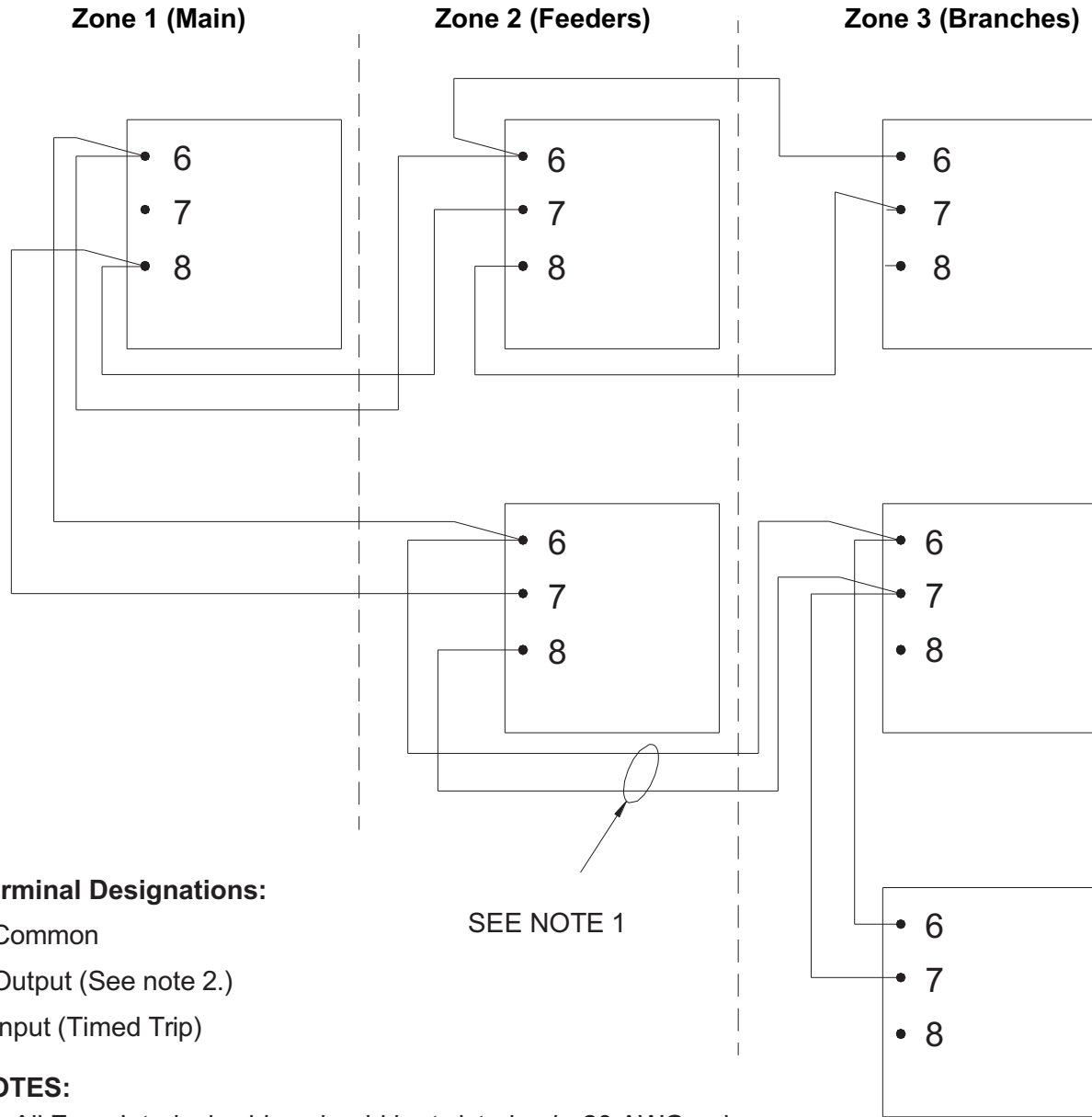

Terminal Designations:

- 6-Common
- 7-Output (See note 2.)
- 8-Input (Timed Trip)

NOTES:

1. All Zone Interlock wiring should be twisted pair, 20 AWG or larger.
2. Limits of 10 upstream units are to be used to a single output.

GFP DIMENSIONS AND MOUNTING

Model GFP Relay [5-60 | 30-360 | 100-1200A]

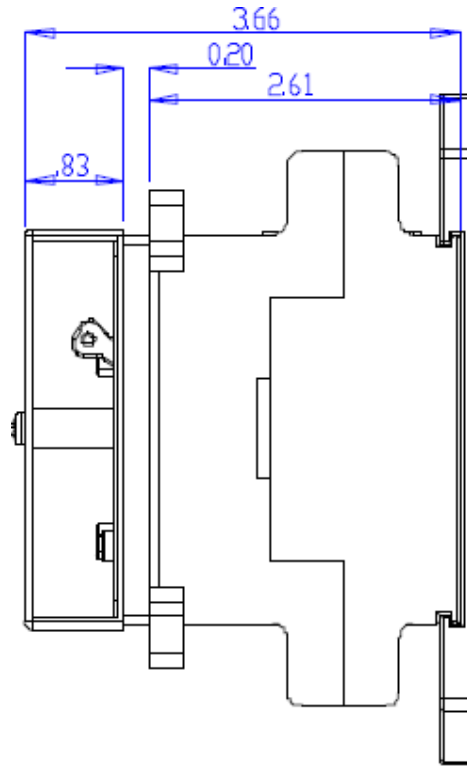
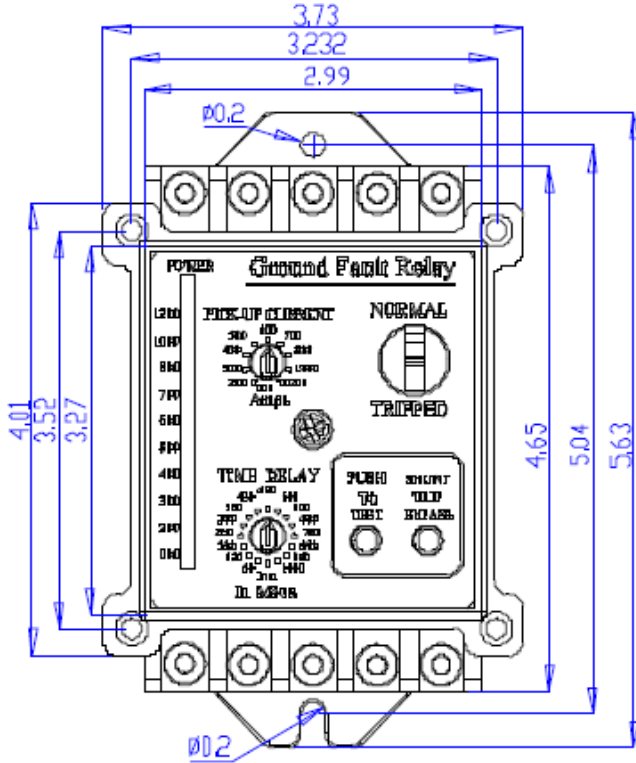

Suggested mounting for Door Mount GFP Relay

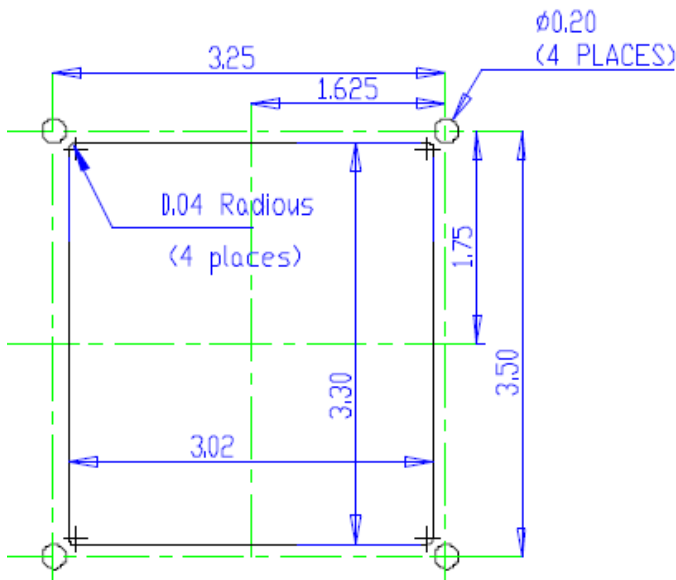

Suggested mounting for Panel Mount GFP Relay



Rev F 06 12 2024