

## TOROIDAL CURRENT TRANSFORMERS

### Model 780 Ratio to 5 (Window Size: 6.50" Dia.)

**Application:** Used with ammeters, watt meters and cross current compensation.

**Frequency:** 50-400 Hz

**Insulation Level:** 600 Volts, 10kV BIL Full Wave

**Standards:** CSA 66.1-06, CSA 66.2-06, IEEE C 57.13, and UL 506

- Terminals are brass studs No. 8-32 UNC with one flat washer, one lock washer and one nut each.
- Approximate weight: 30 lbs.

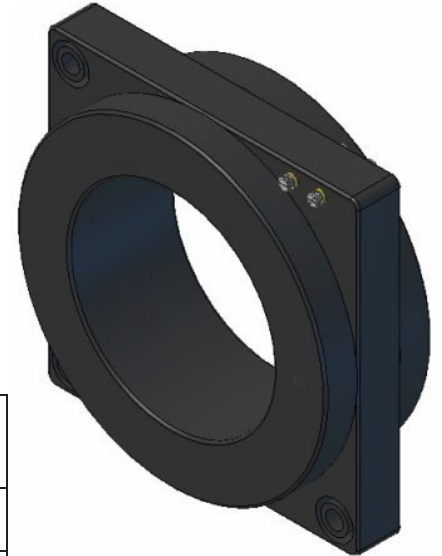

Model	Ratio	Relay Class	ANSI METERING CLASS AT 60 Hz					CONTINUOUS THERMAL RATING FACTOR	
			B0.1	B0.2	B0.5	B0.9	B1.8	@ 30 DEG C	@ 55 DEG C
780-500	50:5	--	4.8	--	--	--	--	2.0	1.5
780-750	75:5	C10	4.8	4.8	--	--	--	2.0	1.5
780-101	100:5	C10	2.4	2.4	4.8	--	--	2.0	1.5
780-151	150:5	C20	1.2	1.2	2.4	4.8	--	2.0	1.5
780-201	200:5	C20	0.6	0.6	1.2	2.4	4.8	2.0	1.5
780-251	250:5	C20	0.6	0.6	1.2	1.2	2.4	2.0	1.5
780-301	300:5	C20	0.3	0.6	0.6	1.2	2.4	2.0	1.5
780-401	400:5	C50	0.3	0.3	0.6	0.6	1.2	2.0	1.5
780-501	500:5	C50	0.15	0.15	0.3	0.6	0.6	2.0	1.5
780-601	600:5	C100	0.15	0.15	0.3	0.3	0.6	2.0	1.5
780-751	750:5	C100	0.15	0.3	0.3	0.3	0.6	2.0	1.5
780-801	800:5	C100	0.15	0.3	0.3	0.3	0.6	2.0	1.5
780-102	1000:5	C100	0.15	0.15	0.15	0.3	0.3	2.0	1.5
780-122	1200:5	C200	0.15	0.15	0.15	0.3	0.3	2.0	1.5
780-152	1500:5	C200	0.15	0.15	0.15	0.15	0.15	1.5	1.33
780-162	1600:5	C200	0.15	0.15	0.15	0.15	0.15	1.5	1.33
780-202	2000:5	C200	0.15	0.15	0.15	0.15	0.15	2.0	1.5
780-252	2500:5	C200	0.15	0.15	0.15	0.3	0.3	1.5	1.33
780-302	3000:5	C200	0.15	0.15	0.15	0.15	0.3	1.5	1.33
780-352	3500:5	C200	0.15	0.15	0.15	0.15	0.15	1.5	1.33
780-402	4000:5	C200	0.15	0.15	0.15	0.15	0.15	1.0	--
780-502	5000:5	C200	0.15	0.15	0.15	0.15	0.15	1.0	--
780-602	6000:5	C200	0.15	0.15	0.15	0.15	0.15	0.8	--

**TOROIDAL CURRENT TRANSFORMERS**  
 Model 780 Ratio to 5 (Window Size: 6.50" Dia.)

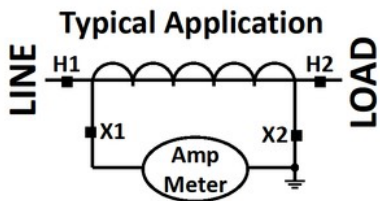
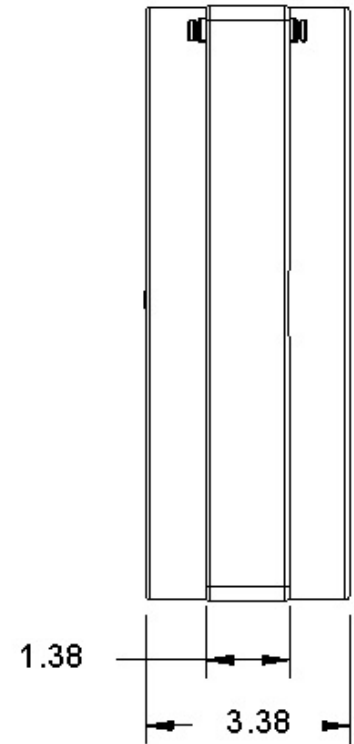
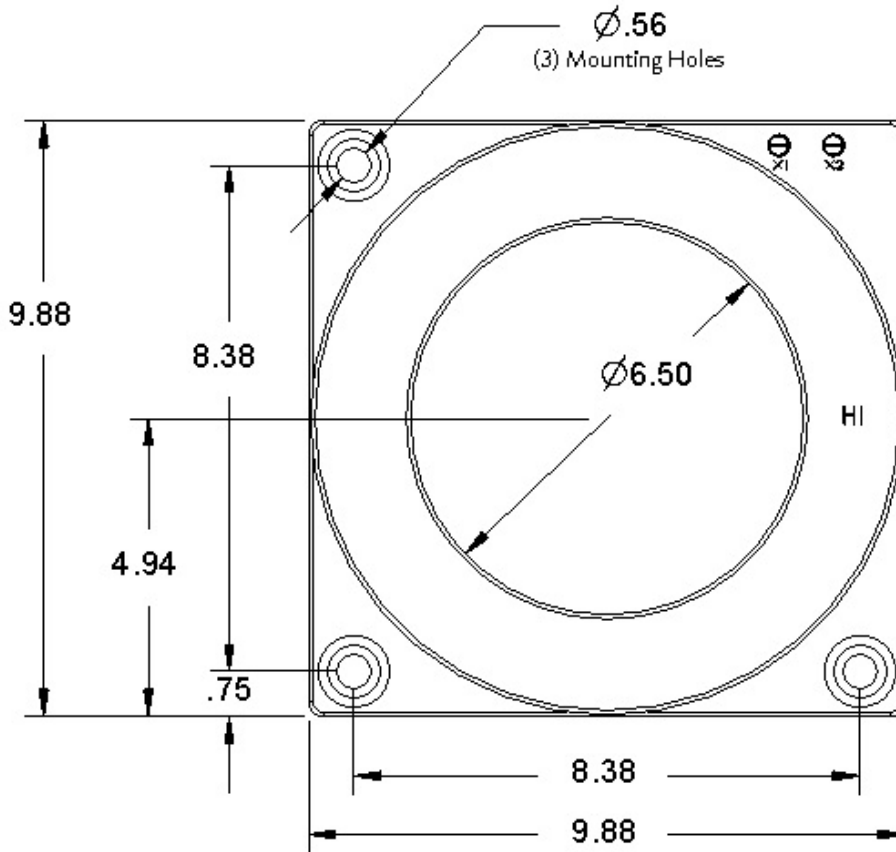

# TOROIDAL CURRENT TRANSFORMERS

## Model 780 Ratio to 5 (Window Size: 6.50" Dia.)

EXCITATION CURVE

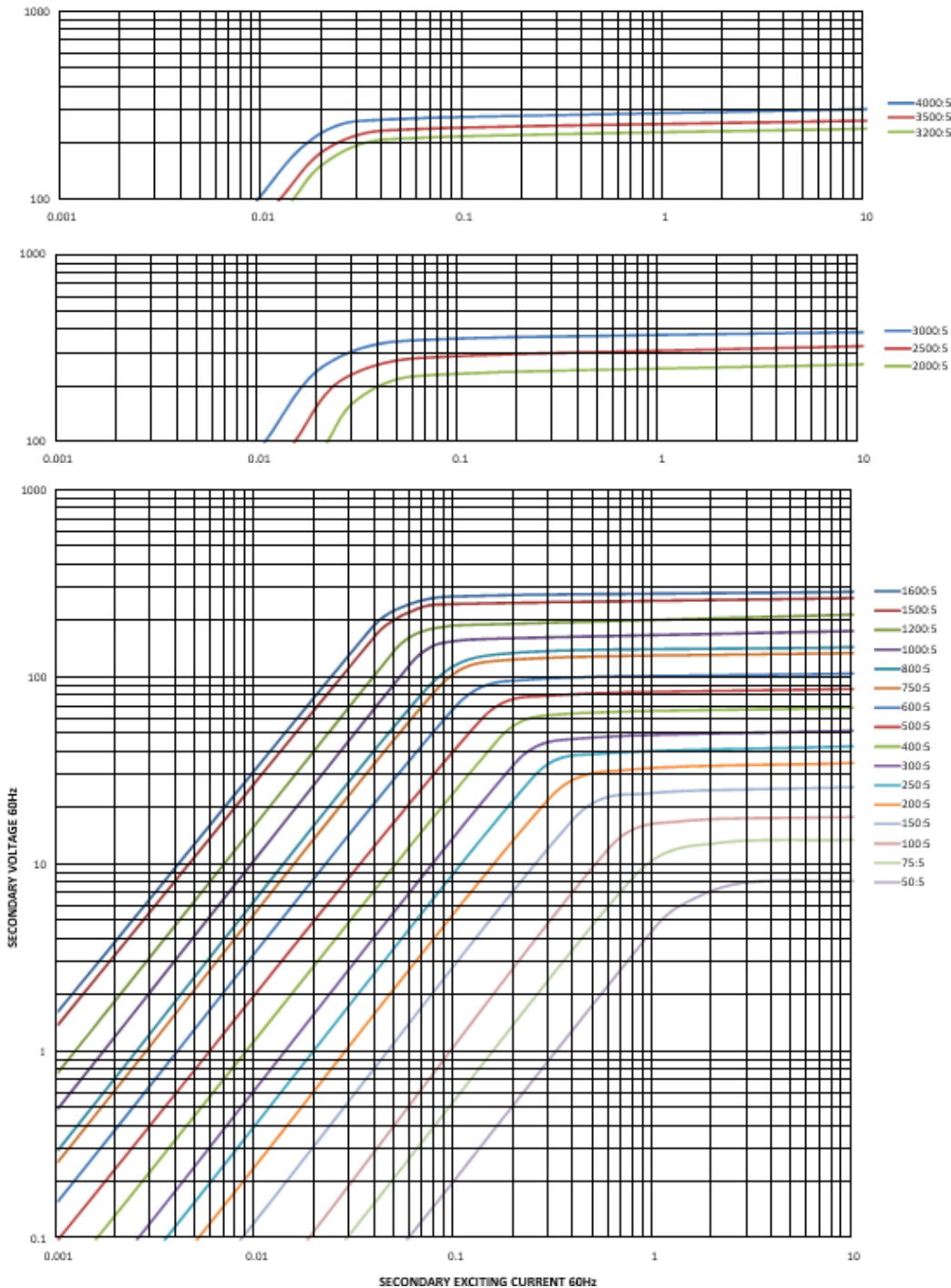

Rev F 06 12 2024