

# GROUND FAULT CURRENT DETECTION

## Model BGFL RELAY [5-60 | 30-360 | 100-1200A]

The BGFL system is designed for electrical equipment protection, not for personnel protection.

**Application:** These Class 1 Ground Fault relays and sensors are used together to provide a system for detecting ground fault current in a grounded AC power system. When the system detects a ground fault that reaches a pre-selected current level and time delay, the relay initiates a trip signal for a shunt trip disconnect device to open and clear the fault.

The relays are also available with interlocks (for coordination of multiple devices in a system) and without interlocks (for single device systems).

**Operating Range:** Trip Currents models are available for 5-60, 30-360 and 100-1200A. The time delay is adjustable from 0.10 to 1 second.

**Input Power:** 2VA plus shunt coil requirements. (Rated @ 120 VAC)

**Input Withstand:** 200,000 Amperes RMS for 3 cycles, 50/60 Hz.

**Nominal Input Voltage:** 120 Volts AC, 125 Volts DC, 48 Volts DC, 24 Volts DC

**Frequency:** 50/60 Hz.

**Ambient Temperature Range:** -30 Deg C. to 60 Deg C.

- Two (2) Styles "Standard" (without interlock) and "Zone Interlocking"
- Integral test panel with "Push to Test" and "Shunt Trip Bypass" pushbuttons for proper testing of device with the ability to trip or not to trip the protective device.
- Power On Indication (LED)
- Positive Visual Trip Indicator.
- Adjustable time delay.
- Discrete current threshold adjustment.
- Clear Plastic Cover
- Electro-mechanical relay output positive "ON" and "OFF"
- Operates with molded case power circuit breakers, bolted pressure switches, or fusible disconnect switches.
- Meets NEC service entrance equipment standards.
- Rear Terminal Kit for Door Mount units
- For Dimensional and physical installation Panel or Door Mounted information see page 7.



Contact Rating		
Device Input Power	Inrush	Continuous
120 VAC	10 A	3A

### How to Order:

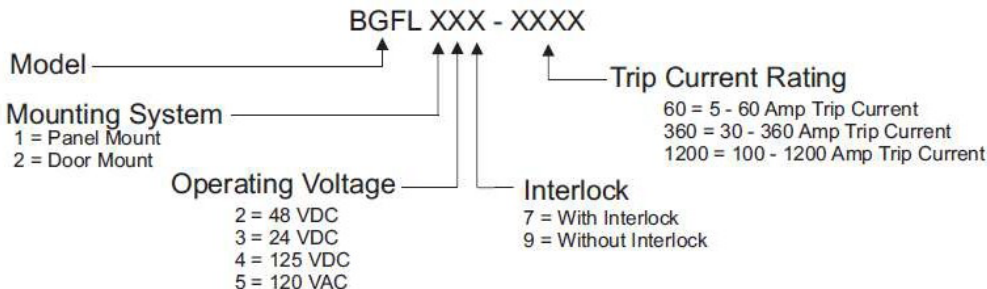

Rev F 06 12 2024

# RECTANGLE GROUND FAULT CURRENT SENSOR

## Model GFL [5-60 | 30-360 | 100-1200A]

The GFL system is designed for electrical equipment protection, not for personnel protection.

**Application:** These Ground Fault Sensors (type GFL) are available in a variety of sizes. Care should be taken when determining the physical size of the sensor window. The Ground Fault Sensor will only respond to ground faults that occur between the position of the sensor and the load. Each sensor comes with both normal and test windings. These sensors are only for use with GFP and BGFL relays.

**Operating Range:** Trip Currents models are available for 5-60, 30-360, and 100-1200A. (Tolerances +/- 15%.)

**Frequency:** 50/60 Hz.

**Insulation Level:** 600 Volt, 10 kV BIL full wave.

- No. 8-32 brass terminals with flat washer, lock washer, and nut.
- Rectangular sensors are available on 5-60A, 30-360A and 100-1200A trip currents.
- Rectangular sensors are also available with take apart option allowing installation without disassembly of the primary bus or cables.
- Sensors are "Zero Sequence" sensors. For application where all three phase (and the neutral if monitored) pass through the same sensor, the direction of current flow is not a factor in the relay's operation.
- If more than one sensor is being used, all sensors must have the H1 side facing the same direction with respect to the current flow.

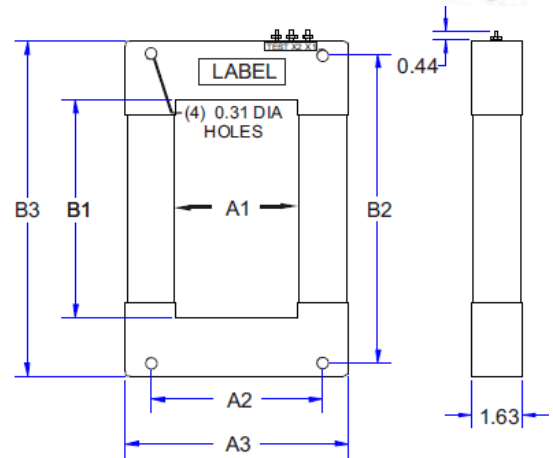

### How to Order:

The table lists the available standard sensor sizes. Any window length can be combined with any window width. Custom sizes are also available.

To order a rectangular sensor, use the Sensor Size table and the Part Number table below.

Example: For a 10.1" x 24" window with a current trip range of 100-1200 and a split core, the part number would be "101x240SC1200".

STANDARD SENSOR SIZES					
A1	A2	A3	B1	B2	B3
4.1	6.4	7.3	7.1	10.0	10.9
5.1	7.2	8.3	11.7	14.5	15.4
5.8	7.0	9.0	14.1	17.0	17.9
8.0	9.5	11.1	18.1	21.0	21.9
10.1	11.6	13.2	24.0	27.0	27.9
—	—	—	30.1	33.0	33.9
—	—	—	36.0	38.9	39.8

GFL	Width Dim "A1" (in 1/10th of inch) See Table	BY	Length Dim "B1" (in 1/10th of inch) See Table	Split Core SC or Blank	Trip Current 5 - 60A = 60 30 - 360A = 360 100 - 1200A = 1200
GFL-	XXX	X	XXX	SC	XXXX

All Rectangular sensors built after January 1 2006 are RoHS Compliant.

Rev F 06 12 2024

# TOROIDAL GROUND FAULT CURRENT SENSOR

## Model GFL [5-60 | 30-360 | 100-1200A]

The GFL system is designed for electrical equipment protection, not for personnel protection.

**Application:** These Ground Fault Sensors (type GFL) are available in a variety of sizes. Care should be taken when determining the physical size of the sensor window. The Ground Fault Sensor will only respond to ground faults that occur between the position of the sensor and the load. Each sensor comes with both normal and test windings. These sensors are only for use with GFP and BGFL relays.

**Operating Range:** Trip Currents models are available for 5-60, 30-360, and 100-1200A. (Tolerances +/- 8%.)

**Frequency:** 50/60 Hz.

**Insulation Level:** 600 Volt, 10 kV BIL full wave.

- No. 8-32 brass terminals with flat washer, lock washer, and nut.
- Sensors are “Zero Sequence” sensors. For application where all three phase (and the neutral if monitored) pass through the same sensor, the direction of current flow is not a factor in the relay’s operation.
- If more than one sensor is being used, all sensors must have the H1 side facing the same direction with respect to the current flow.

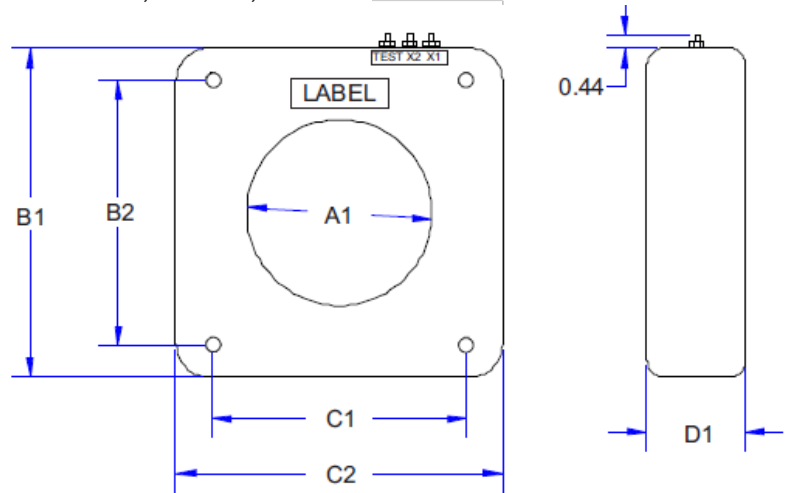

### Trip Current 5-60 AMPS

Model Number	Sensor Dimensions					
	A1	B1	B2	C1	C2	D1
GFL325T-1	3.25	5.73	4.7	4.7	5.73	1.15
GFL425T-1	4.25	6.17	N/A	4.86	5.92	1.15
GFL631T-1	6.31	8.5	6.75	6.75	8.5	1.28
GFL825T-1	8.25	10.48	8.5	8.5	10.48	1.53

### Trip Current 100-1200 AMPS

Model Number	Sensor Dimensions					
	A1	B1	B2	C1	C2	D1
GFL325T-2	3.25	5.73	4.7	4.7	5.73	1.15
GFL425T-2	4.25	6.17	N/A	4.86	5.92	1.15
GFL631T-2	6.31	8.5	6.75	6.75	8.5	1.28
GFL825T-2	8.25	10.48	8.5	8.5	10.48	1.53

### Trip Current 30-360 AMPS

Model Number	Sensor Dimensions					
	A1	B1	B2	C1	C2	D1
GFL325T-3	3.25	5.73	4.7	4.7	5.73	1.15
GFL425T-3	4.25	6.17	N/A	4.86	5.92	1.15
GFL631T-3	6.31	8.5	6.75	6.75	8.5	1.28
GFL825T-3	8.25	10.48	8.5	8.5	10.48	1.53

Rev F 06 12 2024

## TYPICAL RESPONSE CURVES Model BGFL

Actual time delay adjustment is continuously adjustable from 0.10 to 1 sec. Time delay tolerance +/-10% of setting

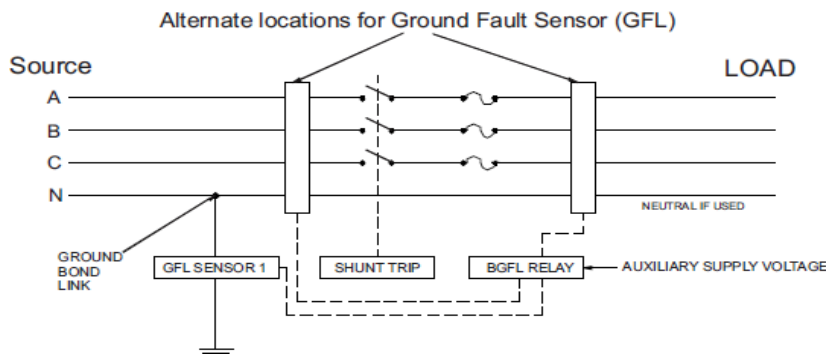
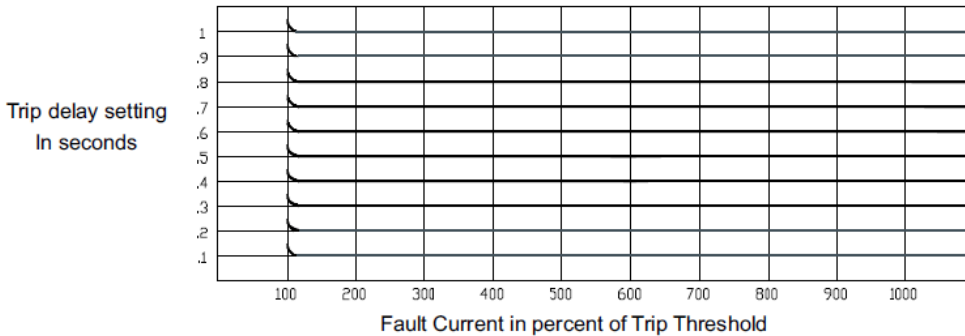

**CAUTION: This test should only be performed by a qualified professional!**

**To determine if the neutral is grounded in only one place at the service entrance in accordance with the "National Electrical Code."**

1. De-energize equipment. (Disconnect Power)
2. Remove ground bond link.
3. Using a megger, measure resistance of each phase and the neutral to ground.
  - In accordance with NEC requirements, the resistance should be 1 mega ohm.
  - Readings as low as 100 Ohms will not affect units rated for 1200 Amps but will affect the 60 Amp and 360 Amp units when set at the lowest settings.
4. Reconnect bond link.
5. Reconnect power and check power indication (LED).

**To test the entire system (including the disconnect device):**

1. Verify control power LED indicator is illuminated.
2. Press the "Push to Test" pushbutton on the BGFL box.
  - The trip indicator will go to the tripped position and the disconnect device will open.
3. Reset the relay and disconnect device.

**To test the BGFL Ground Fault Sensor and Relay only:**

1. Verify control power LED indicator is illuminated.
2. Press and hold the "Shunt Trip Bypass" pushbutton on the BGFL box.
3. Press the "Push to Test" pushbutton.
  - The Ground Fault Relay will trip.
4. Reset the relay, and then release the "Shunt Trip Bypass" pushbutton.

**CAUTION:** All appropriate safety precautions must be followed for the installation of these devices including de-energizing the incoming power prior to installation. It is recommended the sensor be installed by a trained Electrician. These sensors must have its secondary terminals shorted or have the relay connected prior to energizing the primary windings.

# TYPICAL BGFL WIRING DIAGRAMS

## Model BGFL

### Typical Wiring Diagram for 120 VAC Units

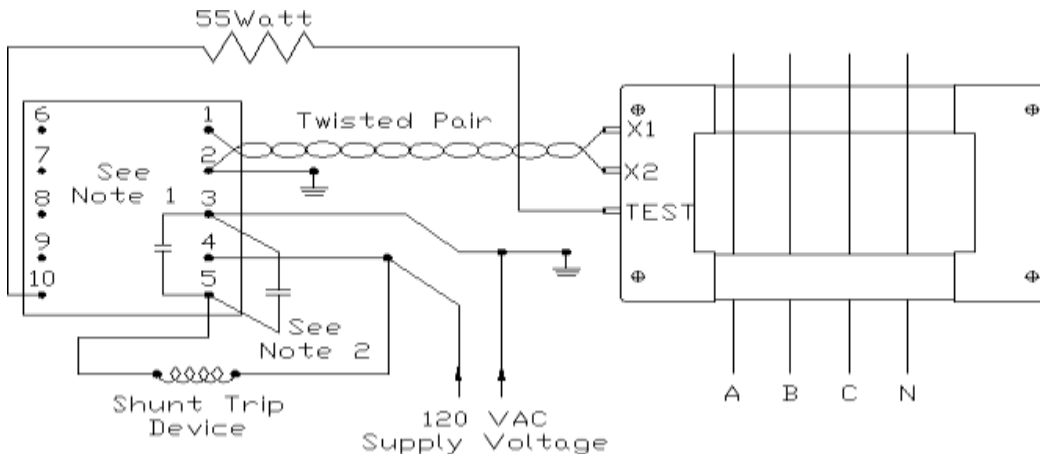

**Notes:**

1. Standard Internal Relay Contacts (NO)
2. Additional protective devices (NO) isolated contacts may be connected in parallel across terminals 3 and 5.

### Typical Wiring Diagram for DC Powered Units

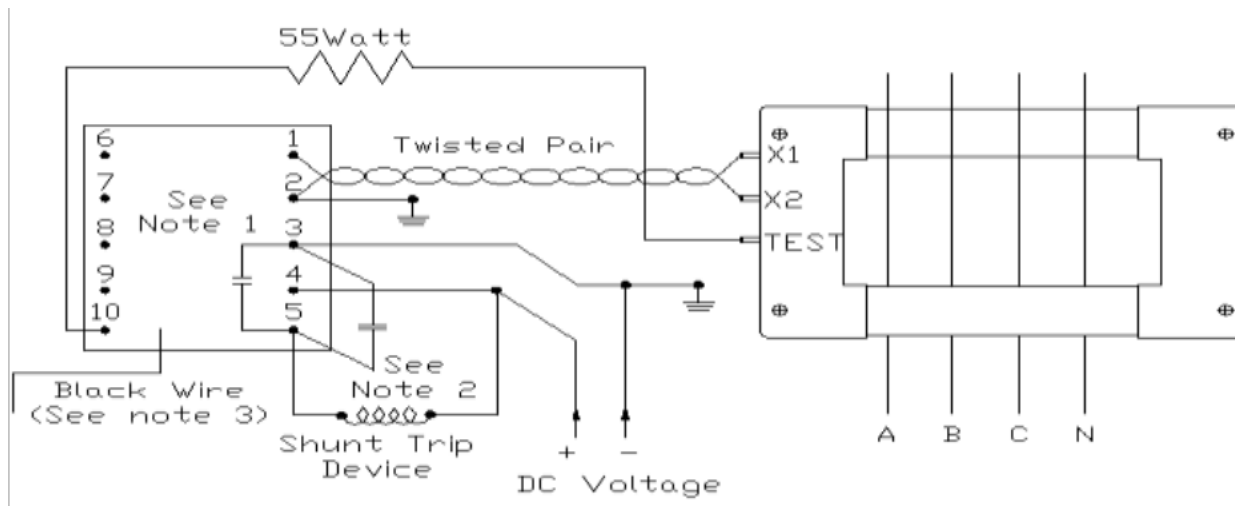

**Notes:**

1. Standard Internal Relay Contacts (NO).
2. Additional protective devices (NO) isolated contacts may be connected in parallel across terminals 3 and 5.
3. The test circuit requires 120Vac be applied to the black wire with the 120 V neutral in terminal 3.

# TYPICAL BGFL WIRING DIAGRAMS

## Model BGFL

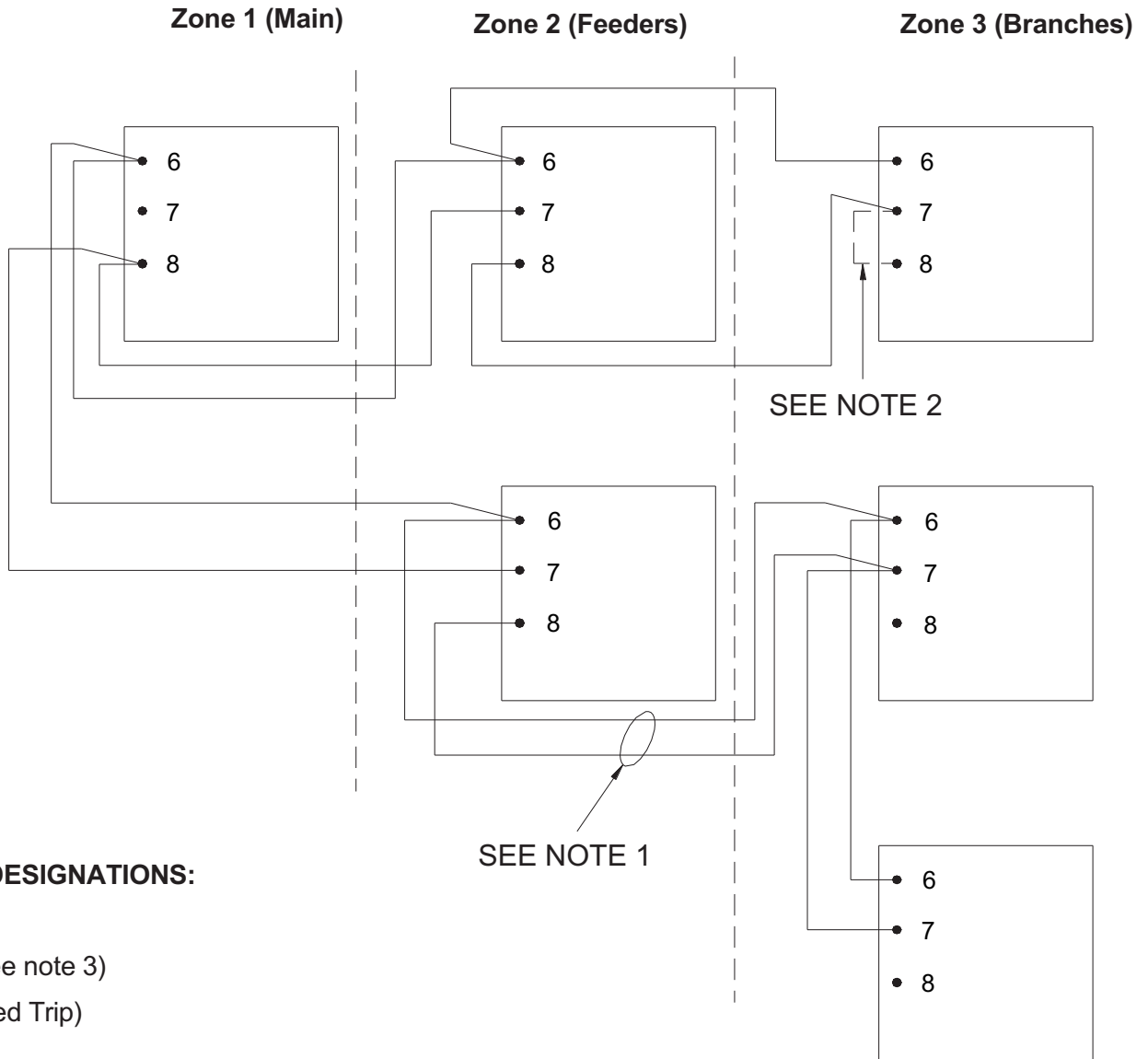

**TERMINAL DESIGNATIONS:**

- 6- Common
- 7- Output (See note 3)
- 8- Input (Timed Trip)

**Notes:**

1. All Zone Interlock wiring should be twisted pair, 20 AWG or larger.
2. Optional Jumper may be used to add time delay to furthest units.
3. Limit of 10 upstream units is to be used to a single output.

# TYPICAL BGFL INSTALLATION

## Model BGFL

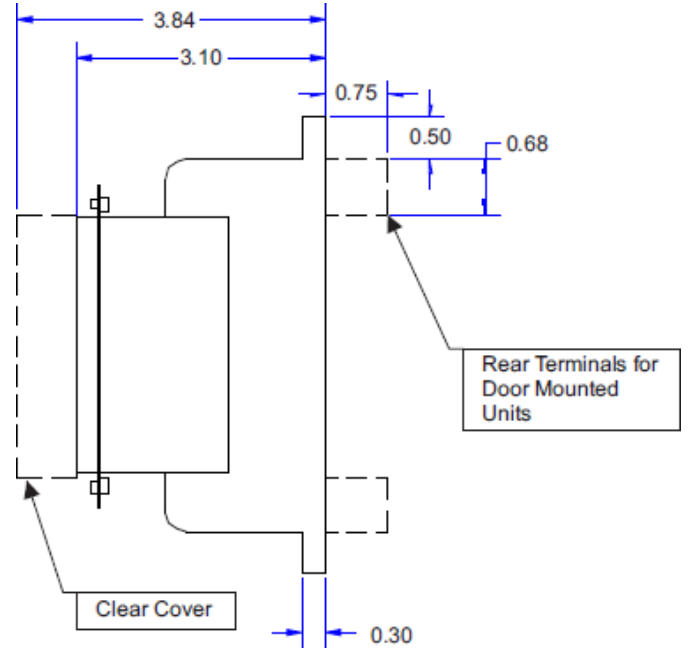
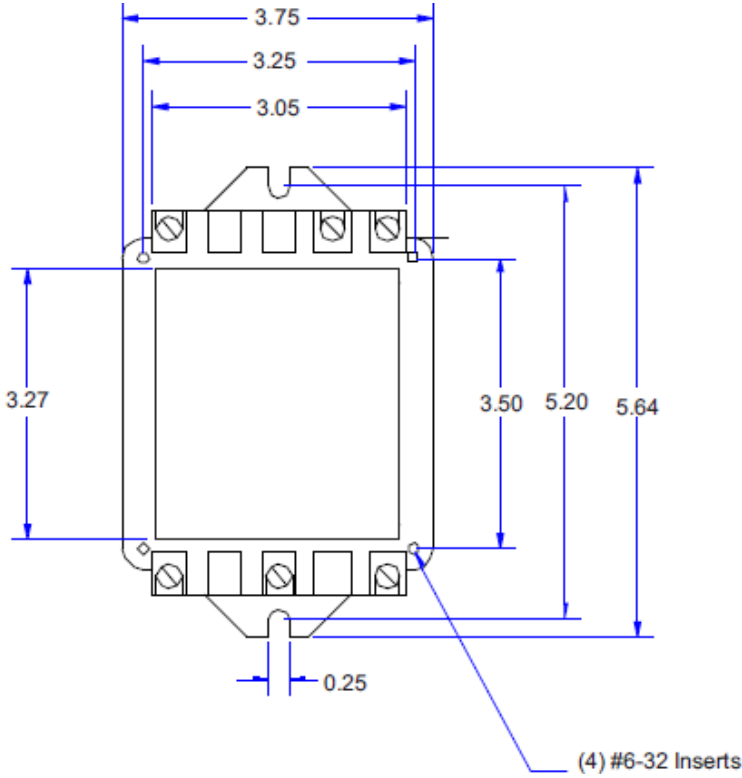

### Suggested mounting for Door Mount GFP Relay

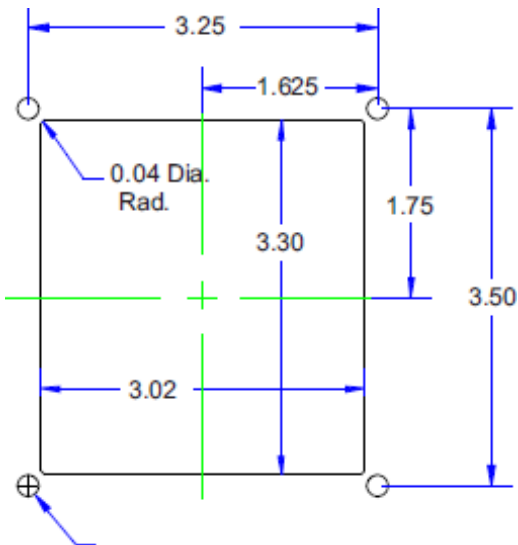

### Suggested mounting for Panel Mount GFP Relay

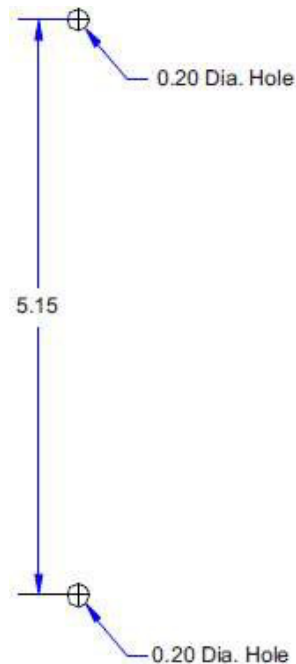

Rev F 06 12 2024