

CAPACITOR TRIP DEVICE

Model CTD-1 and CTD-2

Application: This device provides a source of energy for circuit breakers and switch trip coil operation during a loss of AC control Voltage.

Nominal Input Voltage: 120 Volts AC, 125 Volts DC

Frequency: 0-400 Hz.

SPECIFICATIONS CTD-1	
Max. Input Voltage	140 Vac, 125 Vdc (Surge Protected)
Capacitance	330uF, +/- 20% @25 Deg. C
Available Energy*	4.72 joules, +/- 20% @25 Deg. C
Short Circuit Protection	Continuous
Normal Output Voltage*	170Vdc (w/ 120 Vac Input) 125Vdc (w/ 125 Vdc Input)
Normal Charge Time**	170mSec.
Operating Temperature	-30 Deg. C. to 60 Deg. C.
Storage Temp Range	-50 Deg. C. to 80 Deg. C.
Mounting	Vertical or Horizontal
Input Surge Protection	Mov Protection to 65 joules single Pulse surge

SPECIFICATIONS CTD-2	
Max. Input Voltage	140 Vac, 125 Vdc (Surge Protected)
Capacitance	1500uF, +/- 20% @25 Deg. C
Available Energy*	21.5 joules, +/- 20% @25 Deg. C
Short Circuit Protection	Continuous
Normal Output Voltage*	170Vdc (w/ 120 Vac Input) 125Vdc (w/ 125 Vdc Input)
Normal Charge Time**	440mSec.
Operating Temperature	-30 Deg. C. to 60 Deg. C.
Storage Temp Range	-50 Deg. C. to 80 Deg. C.
Mounting	Vertical or Horizontal
Input Surge Protection	Mov Protection to 65 joules single Pulse surge

* Trip capacitor fully charged at nominal AC input voltage.

** Charge time from full discharge to 90% of max. capacitor charge at 25 Deg. C.

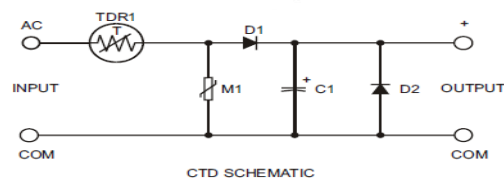
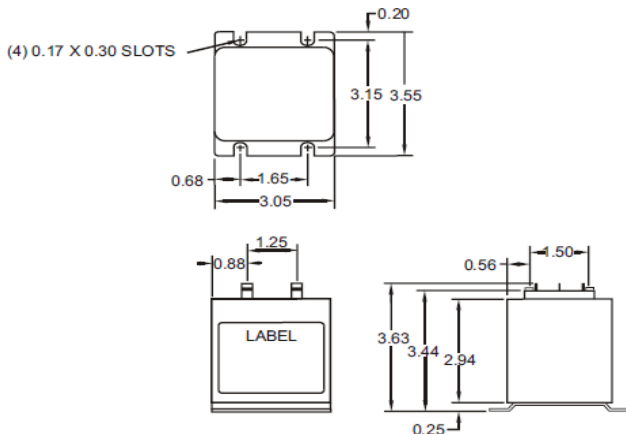

These devices are protected against inadvertent short circuits, input from line surges and inductive kickback from trip coils.

Nominal 120Volts AC or 125 DC is applied between "AC" and "COM" terminals. This voltage is half wave rectified and applied across the trip capacitor to give the output trip voltage. The charge stored in the capacitor (330uF or 1500uF) is available between "+" and "COM" terminals for the trip coil operation. The half wave rectification circuitry provides the advantage of maintaining a common neutral connection from the input and output while still maintaining the charge in the capacitor after a loss of control power.

The capacitor is continuously charged when control power is applied. This provides energy for normal trip coil operation. Because mechanical relays are not used, energy from the trip coil is immediately available with the loss of control power. When the control power returns, the capacitor will recharge and will be able to supply energy for the next trip coil operation.

FOR RoHS COMPLIANT PART, CONTACT SALES REPRESENTATIVE FOR AVAILABILITY.

Rev F 06 12 2024