

GROUND FAULT CURRENT DETECTION

Model GFM Relay 353 | 363 | 453 | 463 (1.5 to 65 Amps)

The GFM system is designed for electrical equipment protection, not for personnel protection.

Application: These Class 1 (Model GFM) Ground Fault protection systems are used to minimize damage to equipment due to arcing ground faults. The GFM system is designed for all polyphase applications and is ideal for motor control, motor control centers and high voltage starters. Systems can be wye or delta, grounded or resistance grounded.

Note: Only for use with Electromagnetic Industries GFM sensors.

Operation: When the ground fault current exceeds a preselected condition (current and time settings) the relay trips. The relay contacts can be connected in the control circuit of a motor starter, to the shunt trip of a circuit breaker or other similar disconnect or alarm device.

Operating Range: Trip Currents models are available for 1.5 to 65 Amps, depending on sensor.

Input Power: Self-powered

Time Delay: Instantaneous to 36 cycles

Frequency: 50/60 Hz.

Ambient Temperature Range: -30 Deg C. to 60 Deg C.

- Inverse time characteristic (to prevent nuisance trip)
- Field adjustable trip relay (trip current)
- Adjustable trip time delay relay (field settable for up to 36 cycles)
- Positive Visual Trip Indicator
- SPDT contacts: Form C, rated for 10 Amps continuous, 23 Amps inrush (250 VAC)
- Door or Panel Mounted options
- Operates with molded case power circuit breakers, bolted pressure switches, or fusible disconnect switches.



How to Order:

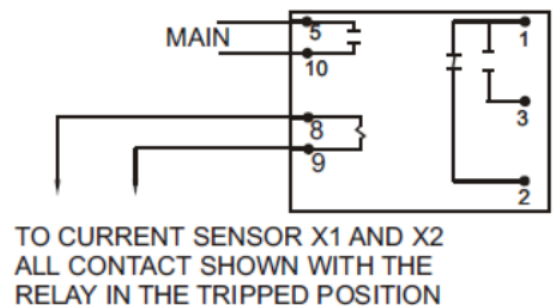
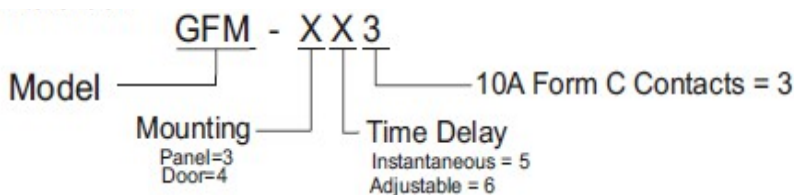

TYPICAL GFM INSTALLATION

Model GFM

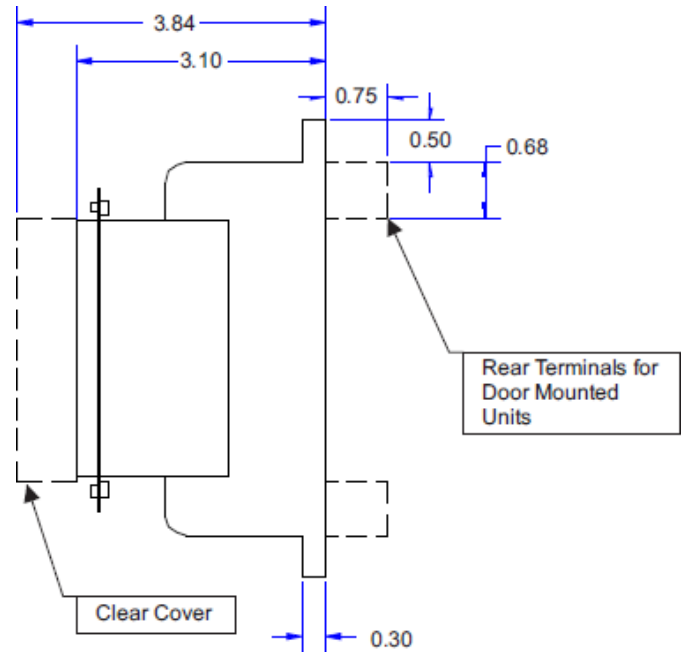
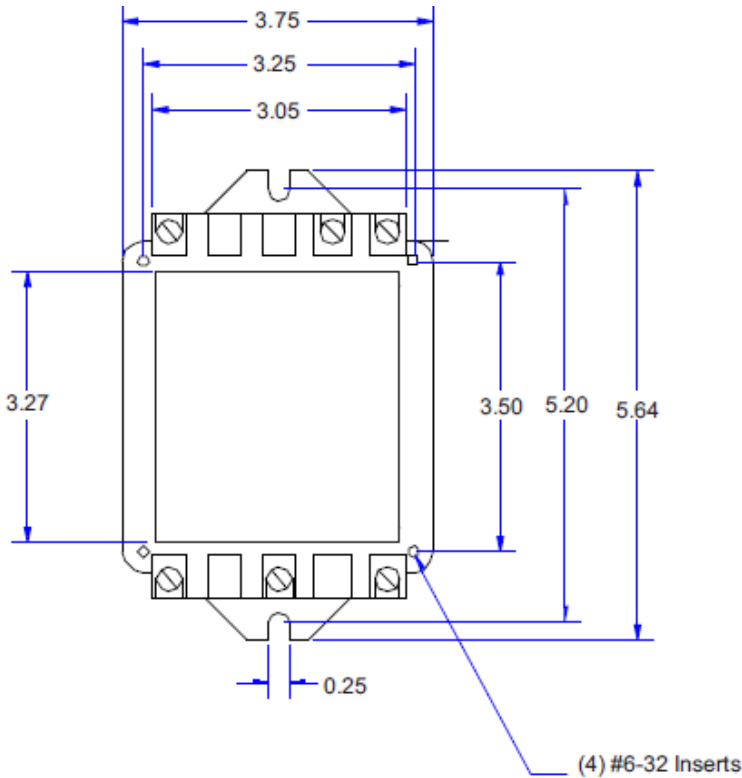

Suggested mounting for Door Mount GFP Relay

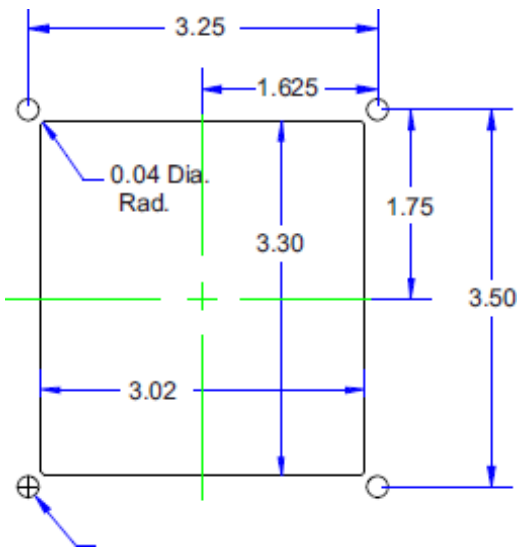

Suggested mounting for Panel Mount GFP Relay

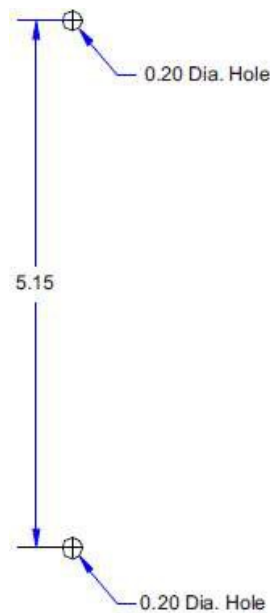

Rev F 06 12 2024

RECTANGLE GROUND FAULT CURRENT SENSORS

Model GFM Relay (1.5 to 65 Amps)

The GFM system is designed for electrical equipment protection, not for personnel protection.

Application: These Ground Fault Sensors (type GFM) are available in a variety of sizes and current trip ranges. Care should be taken when determining the physical size of the sensor window. The Ground Fault Sensor will only respond to ground faults that occur between the position of the sensor and the load.

Note: Only for use with Electromagnetic Industries GFM relays.

Operating Range: Trip Currents models are available for 6-30, 9-39 or 15-65 with current tolerance being +/- 15%.

Insulation Level: 600 Volt, 10 kV BIL full wave. No. 8-32 brass terminals with flat washer, lock washer, and nut.

Frequency: 50/60 Hz.

CAUTION: All appropriate safety precautions must be followed for the installation of these devices including de-energizing the incoming power prior to installation. It is recommended the sensor be installed by a trained electrician.

This sensor must have its secondary terminals shorted, or have the relay connected prior to energizing the primary circuit.

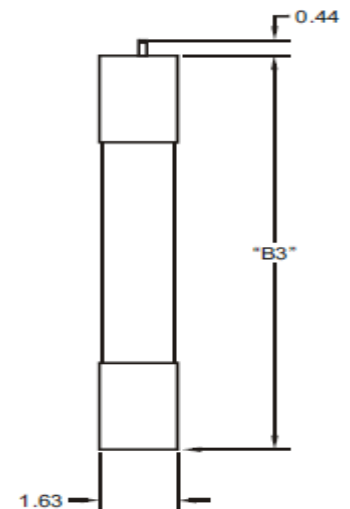
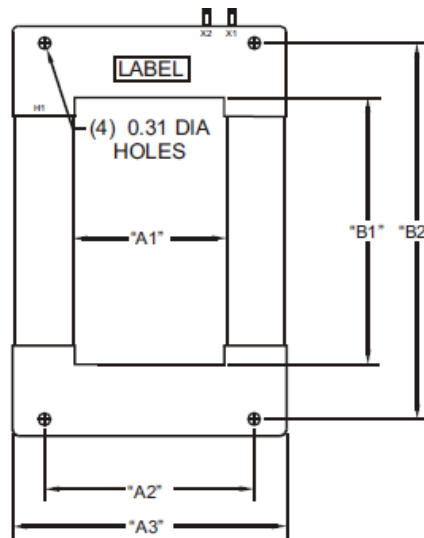
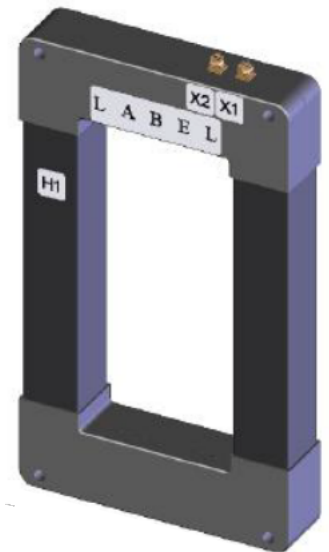

How to Order:

Model Number	Trip Current	STANDARD SENSOR SIZES					
		A1	A2	A3	B1	B2	B3
GFM 041 x 071	6-30A	4.1	6.4	7.3	7.1	10	10.9
GFM 080 x 141	9-39A	8	9.5	11.1	14.1	17	17.9
GFM 080 x 117 SC*	15-65A	8	9.5	11.1	11.7	14.5	15.4

*The "SC" indicates a Split Core design allowing for installation without disassembling of existing primary bus or cable.

TOROIDAL GROUND FAULT CURRENT SENSOR

Model GFM Relay (1.5 to 65 Amps)

The GFM system is designed for electrical equipment protection, not for personnel protection.

Application: These Ground Fault Sensors (type GFM) are available in a variety of sizes and current trip ranges. Care should be taken when determining the physical size of the sensor window. The Ground Fault Sensor will only respond to ground faults that occur between the position of the sensor and the load.

Note: Only for use with Electromagnetic Industries GFM relays.

Operating Range: Trip Currents models are available for 6-30, 9-39 or 15-65 with current tolerance being +/- 15%.

Insulation Level: 600 Volt, 10 kV BIL full wave. No. 8-32 brass terminals with flat washer, lock washer, and nut.

Frequency: 50/60 Hz.

CAUTION: All appropriate safety precautions must be followed for the installation of these devices including de-energizing the incoming power prior to installation. It is recommended the sensor be installed by a trained electrician.

This sensor must have its secondary terminals shorted, or have the relay connected prior to energizing the primary circuit.

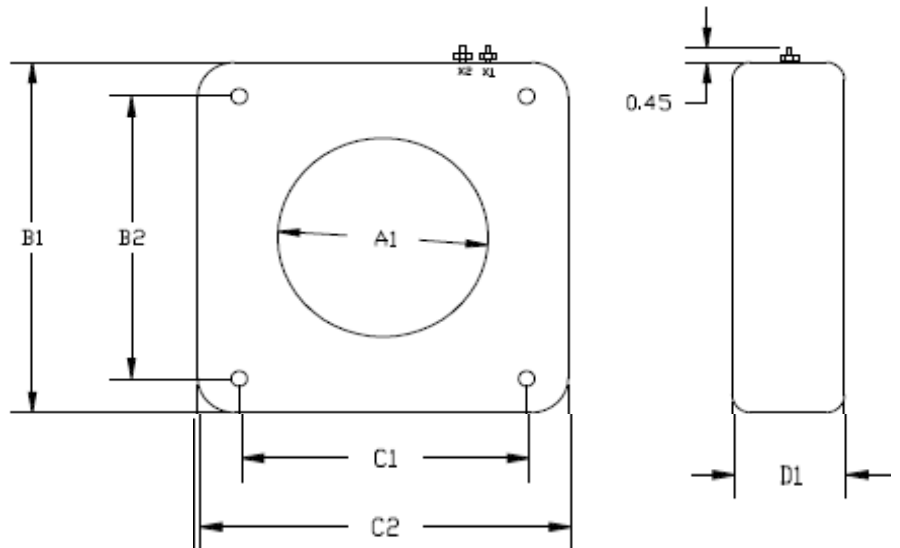

How to Order:

Model Number	Trip Currents	SENSOR DIMENSIONS					
		A1	B1	B2	C1	C2	D1
GFM 094	2.0 to 8.5	1.13	2.68	N/A	N/A	2.40	2.00
GFM 156	3.8 to 18	1.56	3.79	N/A	N/A	3.53	2.15
GFM 250	3.5 to 11	2.50	5.10	N/A	3.75	4.63	3.00
GFM 375	4 to 12	3.75	6.31	4.75	4.75	5.96	3.00
GFM 375D*	3.5 to 11 & 10 to 36	3.75	6.31	4.75	4.75	5.96	3.00
GFM 425	5 to 18	4.25	6.73	5.43	5.44	6.73	1.28
GFM 462	4 to 12	4.62	7.12	5.75	5.75	7.00	4.00

*The "SC" indicates a Split Core design allowing for installation without disassembling of existing primary bus or cable.

ADJUSTABLE DELAY TYPES

Model GFM (Typical Response Curves)

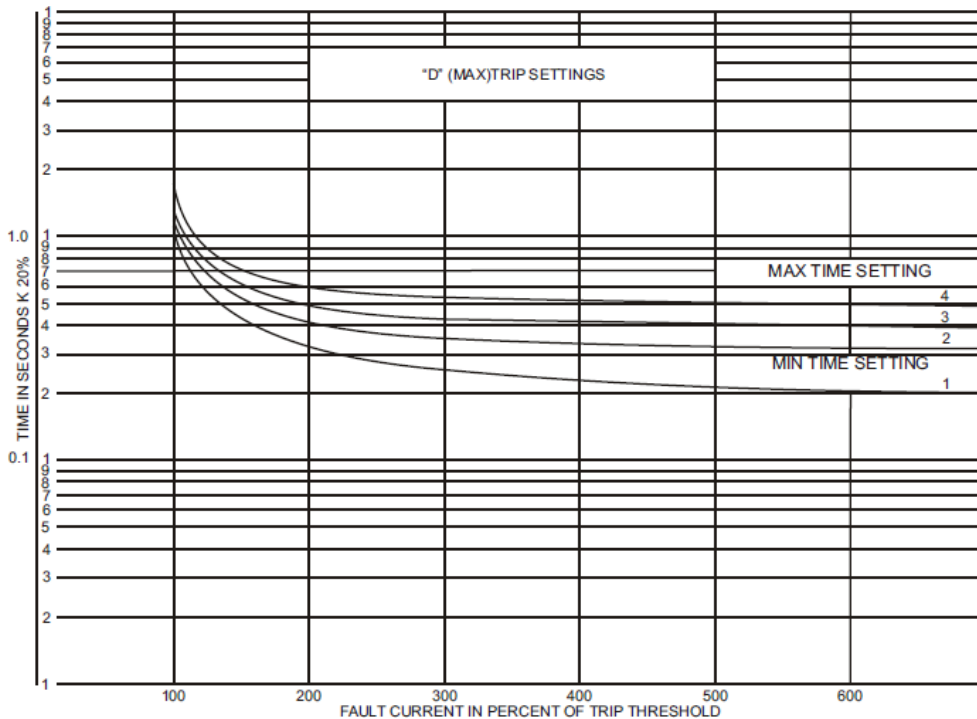
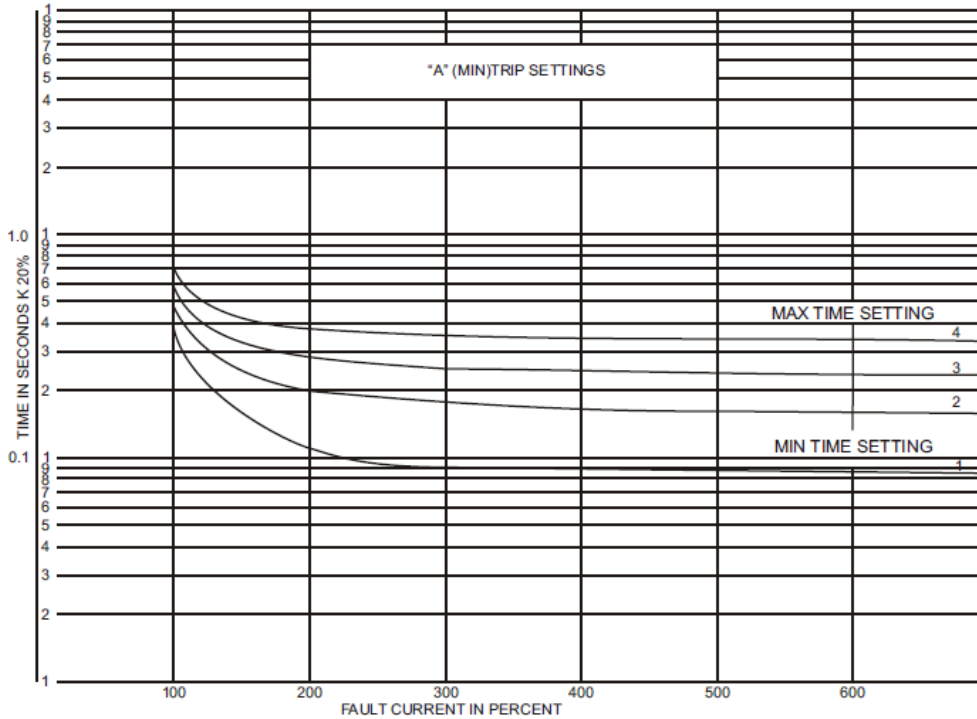

Rev F 06 12 2024

FIXED DELAY TYPES

Model GFM (Typical Response Curves)

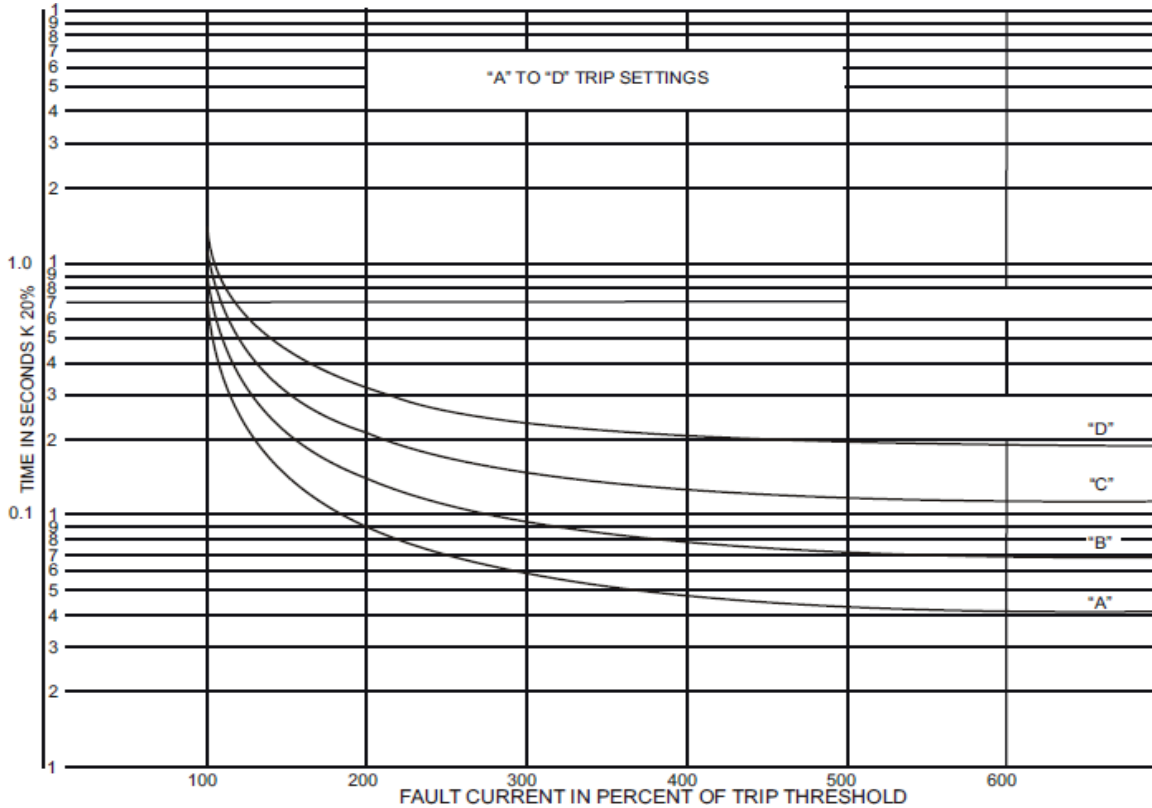

GFM Test Procedure:

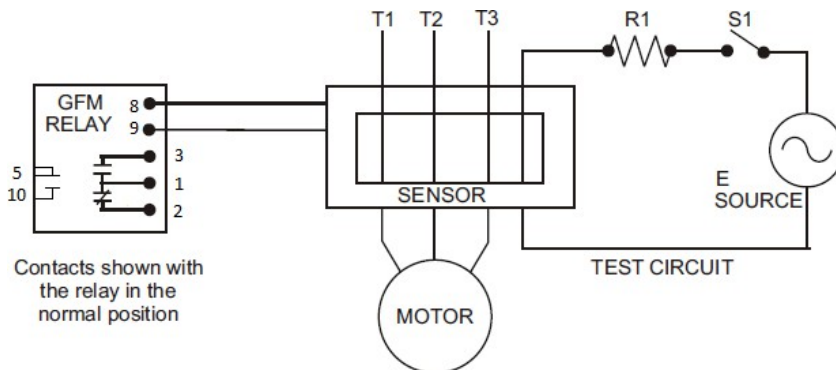

A simulated fault current can be applied by the above test circuit. An appropriate value of R1 should be selected to apply a minimum of 1.5 times the maximum trip rating of the sensor.

1. Assure that the GFM relay is in "NORMAL" (reset) position.
2. Close switch S1 and check for relay response. Relay handle will move to the tripped position.
3. Open S1, reset the relay and remove the test circuit from the system. System is now back to normal.

THE ABOVE TEST PROCEDURES SHOULD BE PERFORMED BY QUALIFIED PERSONNEL ONLY.