

OPEN CIRCUIT PROTECTION

Model 3 OCP

Application: Open circuit protection for the relay classes through C800 and all metering classes.

Frequency: 50-400 Hz.

Ambient Temperature Range: -30 Deg. C. To +55 Deg. C.

Normal Secondary Current: 5 Amps AC.

Short Time Overcurrent: 100 Amps for 1 Sec. (80 Amps for 2 Sec.).

Max Continuous Current: 10 Amps through one element or 7.5 Amps through all three independent elements.

Terminals: Copper with brass slotted pan head screws, #8-32 X 1/4, with cupped washers.

Weight: 1.2 lbs.

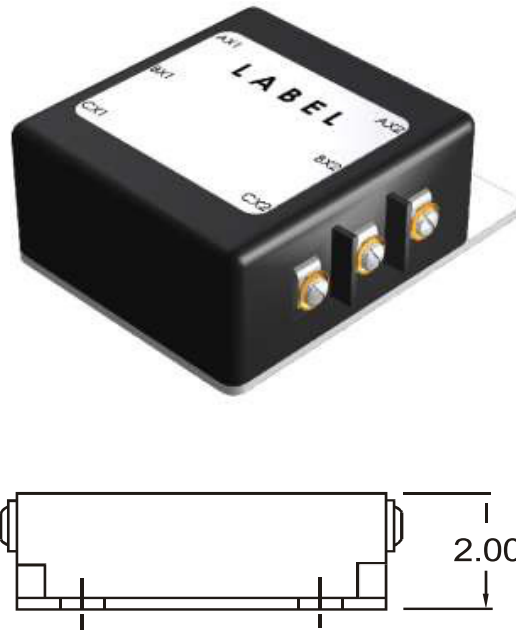
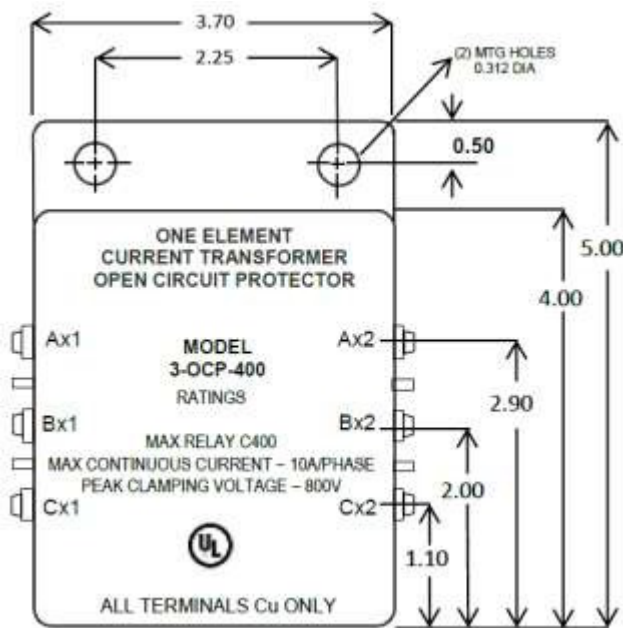

3 ELEMENT OPEN CIRCUIT PROTECTOR			
Model Number	Recommended CT Relay Class	Clamping Peak Voltage Limit (V Peak Nom.)	Standard Burden (ohms)
3-OCP-100	Thru C100	200	1
3-OCP-200	C200	400	2
3-OCP-400	C400	800	4

OPEN CIRCUIT PROTECTION

Model 3 OCP

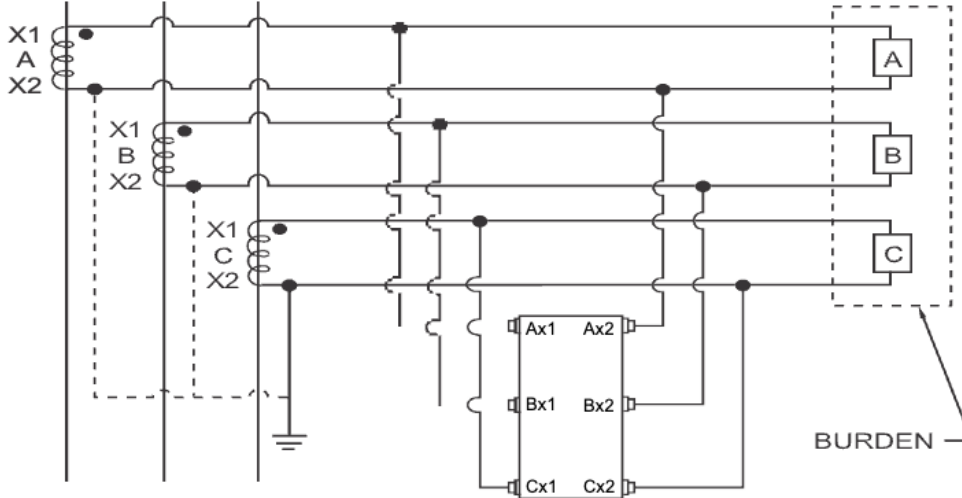

TYPICAL
3 ELEMENT CONNECTION DIAGRAM
3-OCP-XXX

A Current Transformer secondary should never be open circuited while the Current Transformer primary circuit is energized. If this situation should occur there is a possibility of developing extremely high voltages which could be dangerous to personnel or cause an insulation breakdown.

The OCP series of Open Circuit Protectors are voltage sensing devices using high speed shorting SCR switches. When the secondary peak voltage exceeds the clamping voltage value, the SCR operates, shorting the C.T. secondary and reducing the voltage to about 2 volts in less than 1/4 cycle. This process repeats each current polarity reversal. The protection is activated each half cycle.

The single element Open Circuit Protector is provided with two terminals for connection across the secondary of the C.T. and in parallel with burden. It can also be connected across the current terminals of a protective relay, meter, or other current operated device without affecting the operation of the device. Secondary polarity of the C.T.'s is not critical to the OCP.

The OCP also provides protection against high secondary voltage transients, which may damage the burden or secondary winding. If the transient voltage exceeds the voltage clamping limit, the Open Circuit Protector will trigger. After triggering, the voltage will fall to about 2 volts and remain there until the next zero crossing of the current waveform at which time the device resets and the cycle repeats as necessary. In the transient mode of protection, triggering will occur only on the half cycle where the transient appears. The leakage current of the OCP is insignificant and will not cause a ratio or phase angle error in the Current Transformer accuracy.

Metering class C.T.'s with a rating factor of 2 could operate up to 10 amps on a continuous basis. The OCP is designed to tolerate both this condition and (80 Amp RMS) for 2 seconds.

How to Order

